

2017



GRAPHIC AND PREMADE PRODUCTS

Daily Deliveries Throughout New England

Roland Truvis
SG-540



Roland Truvis
VG-640



GRAPHTEC



CE600 Series



FC8600 Series

Roland
Authorized Dealer



GRAPHTEC



Nikkalite™ **Results™**



ECONOMAG



125 Amara! St. East Providence RI, 02915

800-327-7562

401-438-1533

Welcome to NEPCO's Digital Media Reference Catalog

NEPCO has been serving the sign and graphics industry since 1928. Our commitment to customer service has earned us more than a thousand returning customers in the Northeast and beyond.

It is in this spirit that we announce our entry into the Marine Canvas Awning Supplies business. We will serve our new industry and customers with the same excellent service that has allowed our company to grow over the years.

Our truck delivery and low minimums are two things that distinguish NEPCO from our competition. Low delivery minimums matched with our everyday low prices and in-stock availability is our recipe for success.

You should also note that we stock more than 10,000 different SKUs in our warehouse... so if there's something you need... we probably have it. Just give us a call!

Consider trying NEPCO for your next supply order. You won't be disappointed.



NEPCO 800-327-7562
401-438-4550
fax 401-438-1533

Order Center Hours

Monday-Friday 7am-5pm

Warehouse/Counter Hours

Monday-Friday 8am-4pm

Our holiday closings can be found on our website.

Order Cut-Offs



Most UPS orders placed by 4pm will ship same day.

Delivery orders placed by 5pm will be delivered on the customer's next scheduled delivery day.

Payment Methods Accepted



Cash or Company Check

NEPCO Account

UPS COD

Our Office and Warehouse is located at:
125 Amara Street
East Providence, RI 02915

Ordering/Shipping

When placing an order, please be certain to give your sales representative all pertinent information i.e. color, size, quantity and all item numbers (if known). Following this procedure will ensure accurate processing of your order. We encourage the use of fax or email.

Our delivery vehicles are standing by to provide accurate, timely delivery with any order received before 5:00PM THE DAY PRIOR TO YOUR SCHEDULED DELIVERY.

Please note that the minimum for delivery will vary based on your location. Call your sales rep for your minimum order. Unsuccessful deliveries may be subject to a re-delivery charge. UPS delivery (next day within Zone 2) will go out the day that the order is placed, as long as it is received prior to 2:00PM.

Returns and Defective Product

Please contact our returns department (Dave at x125) and a return authorization number will be assigned. All return claims must be made within 30 days of the invoice date. Defective items do not apply. Any unused items must be returned in its original packaging. We reserve the right to charge a fifteen (15%) percent restocking and handling fee

on all returnable merchandise.

At no time, will NEPCO accept the return of lamps that are out of their case, even if they were purchased out of their case. NEPCO reserves the right to refuse the return of any item. (Our driver will test all bulbs for you on delivery)

NET Terms

Open accounts are available to qualified companies on credit approval. Open accounts carry net 30 terms with interest charges of one and one half (1.5%) percent per month levied against all delinquent accounts.

To open an account, please contact your sales representative. They will ensure that you are emailed a credit application package from our credit department. Please allow up to 30 days for approval notification. Until such time, all accounts will be on a pre-paid or COD (credit card or company check) basis.

Return of Checks Due to Insufficient Funds

Processing bounced checks is costly, so we will automatically add a \$30.00 charge to your account for any and all checks that do not clear the bank.

Please call us if you have any questions!

Premium Digital Media

DPF 6500	4
DPF 4600LX.....	4
DPF 6100 XLP.....	4
DPF 6000 RP Clear.....	5
DPF 6000 XRP.....	5
DPF 8000	5
Orajet 3751RA.....	6

Intermediate Digital Media

DPF 4500 GLX/MLX.....	7
DPF 4560 GT.....	7
DPF 4500 G	7
DPF 510	8
Orajet 3641.....	8
Orajet 3640.....	8
Orajet 3164.....	9
Orajet 3621.....	9
Orajet 3165.....	9
Orajet 3551RA.....	10
Ritrama 3-9292	10
FDC 7270.....	10
Orajet 3850.....	11

Wrap Kit

DPF 4600LX.....	12
DPF 6000 XRP.....	12
Arlon 3420	12
Arlon 3220	12
Arlon 3210	12

Premium Overlaminates

Arlon 3210	13
Arlon 3220	13
Ritrama 3-8957	13
Oraguard 290	14
Oraguard 290F.....	14
3M 8518.....	14

Intermediate Overlaminates

Arlon 3420	15
Arlon 3510	15
Oraguard 210	15
Oraguard 215	15
DPF 4500 G	15

Specialty

DPF 207	17
DPF 206	17
Orajet 3620.....	17
Ritrama 3-2287	17
Orajet 3850.....	18
DPF 210	18
FDC 7270.....	18
FDC 7521 Mesh.....	18
DPF 6500	19
EconoMag	19
Magic Stick2	19

Digital Papers

Magic Eco-Satin.....	20
Magic GFIOP212.....	20
Magic GF Photo.....	20
Magic GF Photo 240.....	20

Banners

DPF 313	21
DPF 315	21
DPF 303	22
FDC 7521 Mesh.....	22
DPF 390	22
DPF 210	23
Top Value 13 Super	23
Top Value 18 Super	23
Top Value 13 Standard Banner.....	23
Top Value 3 Flag	24

Printable Heat Transfer Vinyl

Siser CADdigital PU.....	25
Siser CADdigital PVC	25
Siser ColorPrint PU.....	25
Results White Opaque.....	25
Results Dye Block.....	26

Reflective Film

DPF 2400	27
Oralite 5600	27
Oralite 5650RA.....	27
Nikkalite M8500 Series	28
Nikkalite 48000 Series.....	28

Index

Index	29-31
-------------	-------

PREMIUM DIGITAL MEDIA



ARLON

DPF 6500 2 mil • 7 Year • Premium Translucent Cast Film

Repositionable ✓ Air Release ✓ Eco-Solvent ✓ Solvent ✓ Latex ✓ UV ✓

Clear Solvent Adhesive

DPF 6500 is a gloss white, cast, translucent film with a permanent pressure-sensitive adhesive. Designed for backlit graphics, DPF 6500 is made of a premium cast facestock with a special lay-flat liner. The film provides superior print resolution and image quality.

Recommended Applications:

- Windows
- Second Surface Signs

SKU	SIZE
4065-3015-020	30"X50YD
4065-5406-020	54"X20YD



ARLON

DPF 4600LX 3.2 mil • 5 Year • Premium Gloss Print Media

Full/Partial Wrap ✓ Repositionable ✓ Air-Release ✓ Removable ✓ Eco-Solvent ✓ Solvent ✓ Latex ✓ UV ✓

Clear Solvent Adhesive

DPF 4600LX is a white gloss high performance film with a tinted, clean removing, repositionable adhesive system. The repositionable light gray adhesive allows for easy installation while ensuring enough opacity for covering up existing graphics or dark substrates. The new LX (Low Profile) X-Scape Technology provides installers the benefit of a bubble-free installation combined with a smooth printed surface that doesn't show the pattern through the print. DPF 4600LX works great for vehicle graphics and wraps.

Recommended Applications:

- Vehicle Wraps and Decals
- Window Graphics
- Real Estate Signage
- POP Displays
- Tradeshow Graphics
- Other Standard Signage

SKU	SIZE
40L6-3015-102	30"X50YD
40L6-5414-102*	54"X20YD



***Wrap Kit Available!**
40L6-KIT54-GLS



ARLON

DPF 6100 XLP 2.0 mil • 7 Year • Premium Clear Cast Film

Full/Partial Wrap ✓ Repositionable ✓ Air-Release ✓ Removable ✓ Eco-Solvent ✓ Solvent ✓ Latex ✓ UV ✓

Clear Solvent Adhesive

DPF 6100 XLP is a gloss white cast film with bubble releasing, tinted, clean removing, repositionable, permanent pressure-sensitive adhesive. The LX (Low Profile) X-Scape Technology allows installers to achieve speedy installation while maintaining a high enough tack to ensure long-term bond. Designed for large format graphics, DPF 6100XLP is made of premium quality cast facestock with a low profile liner. The adhesive system is designed to provide excellent opacity as well as easy installation. The film provides superior conformability around rivets, curves, contours and channels.

Recommended Applications:

- Full Vehicle Wraps
- Partial Vehicle Wraps
- Fleet Wraps

SKU	SIZE
461L-3015-02	30" X 50YD
461L-4815-02	48" X 50YD
461L-5415-02	54" X 50YD



Guaranteed to offer the lowest price to our loyal customers



DPF 6000 RP CLEAR 2.0 mil • 7 Year • Premium Clear Cast Film

Full Wrap ✓ Eco-Solvent ✓ Solvent ✓ Latex ✓ UV ✓

Clear Solvent Adhesive

DPF 6000 RP Clear is a gloss clear cast film with clear, high tack, permanent pressure-sensitive adhesive. Designed for large format graphics, DPF 6000RP Clear is made of premium quality cast face stock with a special lay-flat liner. The special adhesive system is designed to provide easy installation.

Recommended Applications:

- Windows
- Second Surface Signs
- Fleet Graphics
- Full Vehicle Wraps
- Partial Vehicle Wraps

SKU	SIZE
46P0-3015-000	30"X50YD
46P0-5414-000	54"X20YD



DPF 6000 XRP 2.0 mil • 7 Year • Premium Clear Cast Film

Full/Partial Wrap ✓ Repositionable ✓ Air-Release ✓ Removable ✓ Eco-Solvent ✓ Solvent ✓ Latex ✓ UV ✓

Clear Solvent Adhesive

DPF 6000 XRP is a gloss white cast film with bubble releasing, tinted, clean removing, repositionable, permanent pressure-sensitive adhesive. The X-Scape Technology™ allows installers to achieve speedy installation while maintaining a high enough tack to ensure long-term bond. Designed for large format graphics, DPF 6000XRP is made of premium quality cast facestock with a lay-flat liner. The adhesive system is designed to provide excellent opacity as well as easy installation. The film provides superior conformability around rivets, curves, contours and channels.

Recommended Applications:

- Full Vehicle Wraps
- Partial Vehicle Wraps
- Fleet Wraps

***Wrap Kit Available!**
40R0-KIT30-GLS
40R0-KIT54-GLS

SKU	SIZE
46R0-5406-002	54" X 20YD
46R0-3015-002*	30" X 50YD
46R0-4815-002	48" X 50YD
46R0-5415-002*	54" X 50YD



DPF 8000 3.5 mil • 7 Year • Industrial Grade Film for Hard-to-Stick Surfaces

Eco-Solvent ✓ Solvent ✓ Latex ✓ UV ✓

Clear Solvent Adhesive

DPF 8000 is a satin white, high-tensile, PVC film with aggressive, permanent pressure-sensitive adhesive. Designed for indoor and outdoor graphics, DPF 8000 White is made of a 100% engineering-grade facestock with a polycoated lay-flat liner. The special adhesive system is designed to stick to "hard-to-stick" and low-energy surfaces such as brick, concrete and stucco walls, and ABS plastic. DPF 8000 White is designed to meet the marking requirements and specifications of the transportation, vending and automotive industries.

Recommended Applications:

- Wall Murals
- ABS Plastics
- Rough Surfaces
- Brick, Concrete & Stucco

SKU	SIZE
4087-3015-002	30"X50YD
4087-5415-002	54"X50YD



Guaranteed to offer the lowest price to our loyal customers

ORACAL® **Orajet 3751RA** 2.25 mil • 8 Year • Wrapping Cast Film

Full/Partial Wrap ✓ Repositionable ✓ Air-Release ✓ Removable ✓ Eco-Solvent ✓ Solvent ✓ Latex ✓ UV ✓

Clear Solvent Adhesive

Orajet 3751RA is an ideal choice for challenging vehicle wraps, ORAJET® Series 3751RA features a low initial tack, repositionable adhesive, cast construction and an advanced air release system for highly conformable performance over difficult curves, corrugations and rivets. Series 3751RA is an 8-year, 2.25-mil film with a smooth surface producing vivid, life-like prints that can be removed with little or no adhesive residue for up to four years. Recommended for use with ORAGUARD® Series 290 or 290GF laminating films.

Recommended Applications:

- Long-term
- Outdoor Signage
- Complex Vehicle
- Fleet Graphics

SKU	SIZE
3751RA-30	30"X50YD
3751RA-54	54"X20YD



RapidAir[™]
AIR RELEASE SYSTEM



ARLON

SLX™ Cast Wrap 2 mil • 7 Year • Premium Cast Digital Film

Full/Partial Wrap ✓ Repositionable ✓ Air-Release ✓ Removable ✓ Eco-Solvent ✓ Solvent ✓ Latex ✓ UV ✓

Clean Removing, Repositionable Adhesive

SLX™ Cast Wrap is a premium gloss white repositionable cast film with FLITE Technology™. Designed for the single installer, this film allows for a fast wrap and superior repositionability for full and partial, vehicle and fleet applications. **FLITE Technology is a lite contact system allowing graphics to float over a substrate until firm pressure is applied.** It guarantees the fastest installation while ensuring long-term bond, conforming effortlessly around rivets, complex curves and deep channels. SLX Cast Wrap offers a vibrant and reliable print quality which is present across Eco-Solvent, Solvent, Latex and UV print systems.

Recommended Applications:

- Vehicle Wraps
- Vehicle Graphics
- Vehicle Decals
- Fleet Graphics

SKU	SIZE
70X0-3015-102	30" X 50YD
70X0-5415-102	54" X 50YD



FLITE
TECHNOLOGY



DPF 4500 GLX/MLX 3.0 mil • 5 Year • Intermediate Calendered Digital Vinyl Film

Air-Release ✓ Eco-Solvent ✓ Solvent ✓ Latex ✓ UV ✓

Clear Solvent Adhesive

DPF 4500 GLX/MLX is constructed of a 3-mil (75 micron) white calendered film offered in gloss or matte and coated with tinted, bubble releasing, permanent pressure-sensitive adhesive. The LX (Low Profile) X-Scape System allows installers to achieve speedy installation while maintaining high enough tack to ensure long-term bond. The polymeric facestock allows for vibrant prints combined with ease of application for short and medium-term graphics.

Recommended Applications:

- Short to Medium-Term Signage
- Real Estate Signage
- POP Displays
- Tradeshow Displays
- Kiosks

SKU	SIZE
40X5-3015-122	30" X 50YD
40X5-4815-122	48" X 50YD
40X5-5415-122	54" X 50YD
40X5-3015-149	30" X 50YD
40X5-5415-149	48" X 50YD



DPF 4560 GT 3.0 mil • 5 Year • Intermediate Calendered Digital Vinyl Film

Eco-Solvent ✓ Solvent ✓ Latex ✓ UV ✓

Clear Solvent Adhesive

DPF 4560 GT is a 3-mil (75 micron) white calendered film offered in gloss and matte with tinted, permanent pressure-sensitive adhesive. Designed for indoor and outdoor promotional graphics, DPF 4560GT/MT is made of a polymeric facestock with a polycoated liner. The special tinted adhesive system is designed for opacity to directly cover existing graphics or dark substrates

Recommended Applications:

- POP Displays
- Outdoor Signage
- Blackout Applications
- Mounted Prints
- Medium-Term Graphics

SKU	SIZE
4046-5415-122	54" X 50YD



DPF 4500 G 3.0 mil • 5 Year • Intermediate Calendered Print Media

Eco-Solvent ✓ Solvent ✓ Latex ✓ UV ✓

Clear Solvent Adhesive

DPF 4500 G is a calendered film with permanent pressure-sensitive adhesive. Designed for indoor and outdoor promotional graphics, DPF 4500G White is made of a calendered facestock with a polycoated liner. The special glossy facestock is designed for applications requiring high gloss or more image "pop."

Recommended Applications:

- POP Displays
- Second Surface
- Windows
- Medium-Term Graphics

SKU	SIZE
4045-3015-100	30" X 50YD
4045-5415-100	54" X 50YD
4045-6015-100	60" X 50YD
4045-5415-122	54" X 50YD



Guaranteed to offer the lowest price to our loyal customers

INTERMEDIATE DIGITAL MEDIA



DPF 510 3.2 mil • 3 Year • Digital Print Pressure-Sensitive Vinyl Film

Eco-Solvent ✓ Solvent ✓ Latex ✓

Clear Solvent Adhesive

DPF 510 is a 3.2-mil (80 micron) calendered film with a clear or tinted, solvent-based pressure-sensitive adhesive. The two-sided polycoated liner provides excellent lay-flat properties. The high-quality adhesive provides far superior adhesion and cohesion properties than water-based adhesive. DPF 510 is available in a white gloss and white matte finish.

Recommended Applications:

- Short to Medium-Term Signage
- Real Estate Signage
- POP Displays
- Tradeshow Displays
- Kiosks

SKU	SIZE
4051-5415-002	54" X 50YD
4051-3015-002T	30" X 50YD
4051-5415-002T	54" X 50YD
4051-5415-202T	54" X 50YD



Orajet 3641 3.0 mil • 4 Year • Soft Calendered PVC Digital Media

Eco-Solvent ✓ Solvent ✓ Latex ✓ UV ✓

Water Based Adhesive

Orajet 3641 is an economical 3 mil, 4-year digital film. Great for short- to medium-term indoor and outdoor applications that require vivid colors and images. ORAJET 3641 features a grey, permanent adhesive that is typically used for a variety of outdoor signage applications, P.O.P. and exhibitions. Available in white gloss and matte finishes.

Recommended Applications:

- Economical short- to medium-term general signage
- Decals
- Name Plates
- Die-Cut Letters
- Pop Displays

SKU	SIZE
3641-30-G	30" X 50YD
3641-54-G	54" X 50YD



Orajet 3640 3.0 mil • 4 Year • Soft Calendered PVC Digital Media

Eco-Solvent ✓ Solvent ✓ Latex ✓ UV ✓

Water Based Adhesive

Orajet 3641 is most economical and popular inkjet films, 3 mil, 4-year ORAJET 3640 provides vivid images and great colors for short to medium-term indoor and outdoor applications. ORAJET 3640 features a clear, permanent adhesive and is typically used for a variety of outdoor signage and banner applications. Available in white gloss and matte finishes.

Recommended Applications:

- Economical short- to medium-term general signage
- Decals
- Name Plates
- Die-Cut Letters
- Pop Displays

SKU	SIZE
3640-30-G	30" X 50YD
3640-54-G	54" X 50YD
3640-30-M	30" X 50YD
3640-54-M	54" X 50YD



Guaranteed to offer the lowest price to our loyal customers



ORACAL **Orajet 3164** 4.0 mil • 4 Year • Soft Calendered PVC Digital Media

Eco-Solvent ✓ Solvent ✓ Latex ✓ UV ✓

Water Based Adhesive

Orajet 3164 is an inkjet media is a great choice for vibrant shorter-term applications. ORAJET 3164 has a clear, water-based permanent adhesive and is ideal for a variety of outdoor signage applications, including short-term promotions, P.O.P. and exhibition graphics. Available in 54" and 60" widths.

Recommended Applications:

- Economical short- to medium-term general signage
- Decals
- Name Plates
- Die-Cut Letters
- Pop Displays

	SKU	SIZE
• Economical short- to medium-term general signage	3164-30-G	30" X 50YD
• Decals	3164-54-G	54" X 50YD
• Name Plates	3164-30-M	30" X 50YD
• Die-Cut Letters	3164-54-M	54" X 50YD

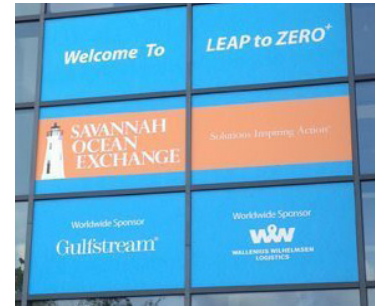

ORACAL **Orajet 3621** 3.0 mil • 4 Year • Soft Calendered PVC Digital Media

Removable ✓ Eco-Solvent ✓ Solvent ✓ Latex ✓ UV ✓

Water Based Adhesive

Orajet 3621 is an economical calendered inkjet media for short-term interior and exterior graphics that require easy removal. ORAJET 3621 has a water-based, removable, grey-pigmented adhesive that delivers great covering power. Designed for flat-surface applications, ORAJET 3621 is available in white gloss and matte finishes.

Recommended Applications:

- Economical short- to medium-term general signage
- Decals
- Name Plates
- Die-Cut Letters
- Pop Displays

	SKU	SIZE
• Economical short- to medium-term general signage	3621-54-G	54" X 50YD
• Decals	3621-54-M	54" X 50YD



ORACAL **Orajet 3165** 3.75 mil • 5 Year • Intermediate Grade Calendered PVC Digital Media

Eco-Solvent ✓ Solvent ✓ Latex ✓ UV ✓

Clear Solvent Adhesive

Orajet 3165 is ideal for general signage applications over flat surfaces including yard signs, banners, and displays. In addition to its advanced air-release liner system, this 5-year, 3.75 mil film features a glossy surface to produce vivid, life-like prints and a grey-pigmented solvent-based adhesive for improved durability and covering power.

Recommended Applications:

- Economical short- to medium-term general signage

	SKU	SIZE
• Economical short- to medium-term general signage	3165-54-G	54" X 50YD
	3165-54-M	54" X 50YD



Guaranteed to offer the lowest price to our loyal customers

INTERMEDIATE DIGITAL MEDIA

ORACAL **Orajet 3551RA** 2.75 mil • 7 Year • Intermediate Grade Calendered PVC Digital Media

Partial Wrap ✓ Repositionable ✓ Air-Release ✓ Removable ✓ Eco-Solvent ✓ Solvent ✓ Latex ✓ UV ✓

Clear Solvent Adhesive

Orajet 3551RA is suitable for everything from building signs for easier vehicle applications. The vinyl adhesive is removable permanently making it possible to reposition the vinyl for 30 minutes after application. 3551RA makes it possible to make perfect air bubble-free installation thanks to the unique Rapid Air technology. The film has the microscopic ducts carrying out any air.

Recommended Applications:

- Economical short- to medium-term general signage
- Vehicle graphics requiring limited conformability

SKU	SIZE
3551RA-30	30" X 50YD
3551RA-54	54" X 50YD



RapidAirTM
AIR RELEASE SYSTEM

RITRAMA **Ritrama 3-9292** 6.0 mil • 5 Year • Intermediate Printable-Removable Matte Vinyl

Removable ✓ Eco-Solvent ✓ Solvent ✓ Latex ✓ UV ✓

Water Based Adhesive

Ritrama 3-9292 is a 6.0-mil intermediate vinyl with a pigmented removable adhesive. This film is designed for point of purchase graphics, bumper stickers and other identification pieces and promotional multi-color labels and decals.

Recommended Applications:

- Window Graphics
- Point of Purchase

SKU	SIZE
3-9292-30/5'	30" X 5FT
3-9292-30	30" X 50YD
3-9292-48	48" X 50YD
3-9292-54	54" X 50YD
3-9292-60	60" X 50YD



FDC **FDC 7270** 3.2 mil • 5 Year • Intermediate Grade Calendered Translucent Vinyl

Eco-Solvent ✓ Solvent ✓ Latex ✓ UV ✓

Clear Solvent Adhesive

FDC 7270 is an intermediate grade calendered translucent vinyl film designed for printing backlit graphics and signage requiring medium-term durability.

Recommended Applications:

- Backlit Graphics
- Signage requiring medium-term durability

SKU	SIZE
7270-5415-049	54" X 50YD



Guaranteed to offer the lowest price to our loyal customers

ORACAL **Orajet 3850** 3.0 mil • 7 Year • Translucent Calendered Digital Media

Eco-Solvent ✓ Solvent ✓ Latex ✓ UV ✓

Clear Solvent Adhesive

Orajet 3850 is a high-performance, 3-mil, 7-year translucent inkjet media which is excellent for producing brilliant backlit signage, both indoors and out. ORAJET® 3850 features a semi-gloss finish for reduced glare and a clear, permanent adhesive for internally illuminated applications that last. Recommended for use with ORAGUARD® 215, 240, 290, 290GF, 293 and 297GF laminating films.

Recommended Applications:

- Long-Term use on Rigid Substrates in Backlit Indoor/Outdoor Applications

	SKU	SIZE
	3850-30	30" X 50YD
	3850-54	54" X 50YD



Did You Know?

The difference between SOLVENT BASED-ADHESIVES and WATER BASED ADHESIVES?

Solvent- Based Adhesives

Solvent-based products are designed for more demanding and longer term applications. The components of this adhesive are combined using solvents, thus allowing a structurally stronger adhesive that is more resistant to chemicals, cleaning agents and wider temperature ranges.

Another important attribute is the ability to wet apply graphics without worry of the adhesive losing bond to the substrate.

Water- Based Adhesives

Products with a water-based adhesive, typically are a low-cost solution for either indoor or short-term outdoor graphic applications. This type of adhesive is found in a wide range of versatile projects like decorative wall graphics, indoor wall murals and way finding signage.

Avoid wet applications when applying water-based adhesive products as this will interfere with the bonding process to the substrate.

Guaranteed to offer the lowest price to our loyal customers

Wrap Kit Media Options



ARLON

DPF 4600LX Partial Wraps & Everyday Use (Low Profile)

With Compatible Overlaminates: 3210

Partial Wrap ✓ Repositionable ✓ Air-Release ✓ Removable ✓ Eco-Solvent ✓ Solvent ✓ Latex ✓ UV ✓

Clear Solvent Adhesive

X-Scape Technology: Adhesive has channels embossed into it to allow air to egress away from high pressure areas (bubbles).

Finish: Once film is applied, the air egress pattern is less visible giving the graphic a smooth finish.

Details: 3 Mil Premium Print Media

SKU	SIZE
40L6-KIT54-GLS	54"X20YD



ARLON

DPF 6000 XRP Cast Full Wraps

With Compatible Overlaminates: 3220

Partial Wrap ✓ Repositionable ✓ Air-Release ✓ Removable ✓ Eco-Solvent ✓ Solvent ✓ Latex ✓ UV ✓

Clear Solvent Adhesive

Repositionable: Adhesive allows applicators to "snap" graphics up with ease.

X-Scape Technology: Adhesive has channels embossed into it to allow air to egress away from high pressure areas.

Details: 2 Mil High Performance Cast

SKU	SIZE
46R0-KIT30-GLS	54" X 20YD
46R0-KIT54-GLS	30" X 50YD





SLX™ Cast Wrap Premium Cast Film with Flite Technology™ With Compatible Overlamine: 3270

Partial Wrap ✓ Repositionable ✓ Air-Release ✓ Removable ✓ Eco-Solvent ✓ Solvent ✓ Latex ✓ UV ✓

Clean Removing, Repositionable Adhesive

Flite Technology: A lite contact system allowing graphics to float over a substrate until firm pressure is applied.

Repositionable: Adhesive allows applicators to “snap” graphics up with ease.

Stays Down in Deep Channels: No primer required to conform and bond in deep channels

Details: 2 Mil Premium Cast Media

SKU	SIZE
70X0-KIT30-GLS	30" X 50YD
70X0-KIT54-GLS	54" X 50YD



FLITE
TECHNOLOGY

BIG SAVINGS when you purchase digital media and overlamine together!

Wrap Kit Overlamine Options



Arlon 3420 3.0 mil • Partial Wraps

Partial Wrap ✓

Clear Solvent Adhesive

SKU	SIZE
3420-KIT30-GLS	30" X 50YD
3420-KIT48-GLS	48" X 50YD
3420-KIT54-GLS	54" X 50YD
3420-KIT30-SAT	30" X 50YD
3420-KIT54-SAT	54" X 50YD



Arlon 3220 2.0 mil • Partial/Full Wraps

Full/Partial Wrap ✓

Clear Solvent Adhesive

SKU	SIZE
3220-KIT30-GLS	30" X 50YD
3220-KIT54-GLS	54" X 50YD
3220-KIT60-GLS	60" X 50YD
3220-KIT54-MAT	54" X 50YD
3220-KIT54-LSTR	54" X 50YD



Arlon 3210 1.3 mil • Partial /Full Wraps

Full/Partial Wrap ✓

Clear Solvent Adhesive

SKU	SIZE
3210-KIT54-GLS	54" X 50YD



Arlon 3270 2 mil • Partial /Full Wraps

Full/Partial Wrap ✓

Clear, Permanent Pressure-Sensitive Adhesive

SKU	SIZE
3270-KIT30-GLS	30" X 50YD
3270-KIT54-GLS	54" X 50YD

Did you know....

Overlaminates acts like a "sunblock" to your printed graphics and helps protect your graphics from scratches, dirty debris and UV exposure.



Arlon 3210 1.3 mil • 7 Year • Premium Cast Overlaminates Pressure-Sensitive Film

Full/Partial Wrap ✓

Clear Solvent Adhesive

Arlon 3210 is constructed of a 1.3-mil (35 micron) gloss cast vinyl film with clear, permanent pressure-sensitive adhesive. Designed to protect printed images and prolong the life of the printed images. Series 3210 provides the same protection as our standard overlaminates while having excellent conformability during installation with a lighter weight film. The gloss finish provides an extra pop to printed graphics.

Recommended Applications:

- Vehicle Wraps
- Fleet Graphics
- Building Wraps
- Long-Term Signage

SKU	SIZE
3210-5415-000	54" X 50YD



Wrap Kit Available!
3210-KIT54-GLS



Arlon 3220 2.0 mil • 7 Year • Premium Cast Overlaminates

Full/Partial Wrap ✓

Clear Solvent Adhesive

Arlon 3220 is constructed of 2-mil (50 micron) cast vinyl film with optically clear, permanent pressure-sensitive adhesive. Designed to protect and prolong the life of printed images for window applications.

Recommended Applications:

- Vehicle Wraps
- Indoor Signage
- Outdoor Signage
- Wall Wraps

SKU	SIZE
3220G-3015-000*	30" X 50YD
3220G-4815-000	48" X 50YD
3220G-5415-000*	54" X 50YD
3220L-5415-100*	54" X 50YD
3220M-3015-800	30" X 50YD
3220M-5415-800*	54" X 50YD
3220S-3015-200	30" X 50YD
3220S-5415-200	54" X 50YD



***Wrap Kit Available!**
3220-KIT30-GLS
3220-KIT54-GLS
3220-KIT54-MAT
3220-KIT54-LSTR



Ritrama 3-8957 2.0 mil • 5 Year • Cast Ultra Gloss Clear Vinyl

Full/Partial Wrap ✓

Clear Solvent Adhesive

Ritrama 3-8957 is a high gloss clear cast vinyl film with a polyester liner, which can be used for overlaminate other vinyl films. The superb clarity of the cast vinyl film and of the acrylic adhesive are enhanced by the smooth polyester liner to keep the image sharp and clear. The overlaminate adhesive wets out quickly to provide a clean image. The stabilized vinyl film offers excellent protection from UV radiation to enhance the weathering of the underlying graphics. The cast vinyl film offers the maximum flexibility.

Recommended Applications:

- Vehicle Wraps
- Vehicle Graphics
- Window Graphics

SKU	SIZE
3-8957-5430	54" X 10YD



Guaranteed to offer the lowest price to our loyal customers

PREMIUM OVERLAMINATE

ORACAL **Oraguard 290** 2.0 mil • 8 Year • Premium Cast PVC Laminating Film

Full/Partial Wrap ✓

Clear Solvent Adhesive

Oraguard 290 is one of the most durable and conformable cast PVC laminating film. ORAGUARD 290 can be used for a wide range of longer-term indoor or outdoor applications, including fleet and large graphic applications. ORAGUARD 290 is an 8-year, 2-mil, highly flexible cast film with a clear, solvent-based adhesive. It's available in gloss and matte, and has a UV protection extension factor of 4 years. Recommended for cold lamination.

Recommended Applications:

- Protection of Long-Term Indoor/Outdoor Digital Print Applications

SKU	SIZE
290-30-G	30" X 50YD
290-36-G	36" X 50YD
290-48-G	48" X 50YD
290-54-G	54" X 50YD

ORACAL **Oraguard 290F** 2.0 mil • 8 Year • Optically Clear Premium Cast PVC Laminating Film

Full/Partial Wrap ✓

Clear Solvent Adhesive

Oraguard 290F is a 2-mil, 8-year optically clear cast film specially designed for use with perforated window graphics films and other applications where the highest levels of clarity and transparency are needed. Available in gloss finishes with a UV protection extension factor of 4 years. Recommended for cold lamination. Also known as the ORAGUARD 290F series.

Recommended Applications:

- Protection of Long-Term Indoor/Outdoor Digital Print Applications

SKU	SIZE
290F-36-G	36" X 50YD
290F-54-G	54" X 50YD

3M **8518** 2.0 mil • 5 Year • Scotchcal Gloss Overlaminates

Full/Partial Wrap ✓

Clear Solvent Adhesive

8518 provides a glossy "paint-like" finish optimized for the fast-growing vehicle wrap market. Its superior conformability characteristics ensure fast and easy application in deep channels and over complex curves. Overlaminates 8518 is designed specifically for use with digitally printed graphics and has limited warranty coverage under the 3M Performance Guarantee.

Recommended Applications:

- Cars & Vans
- Illuminated Signs
- Labels
- Non-Illuminated Signs
- Trains & Busses
- Trucks & Trailers
- Walls & Windows
- Watercraft

SKU	SIZE
3M851854540	54" X 50YD



Guaranteed to offer the lowest price to our loyal customers



Arlon 3270 2.0 mil • 7 Year • Premium Cast Overlamine Pressure-Sensitive Film

Full/Partial Wrap ✓

Clear, Permanent Pressure-Sensitive Adhesive

Arlon 3270 overlamine is a premium cast overlamine available in a gloss finish and is designed to protect and extend the life of printed graphics. Whether your application demands installation into deep channels, rivets, compound curves or a smooth wall, Series 3270 can offer lasting performance and durability. Series 3270 extends the life of the graphics by 2 years. When used independently, Series 3270 is rated for outdoor durability up to 7 years.

Recommended Applications:

- Vehicle Graphics
- Vehicle Decals
- Fleet Graphics

SKU	SIZE
3270G-3015-000	30" X 50YD
3270G-5415-000	54" X 50YD

INTERMEDIATE OVERLAMINATE



Arlon 3420 3.0 mil • 5 Year • Premium Calendered Overlaminates

Partial Wrap ✓

Clear Solvent Adhesive

Arlon 3420 is constructed of a 3-mil (75 micron) calendered vinyl film with clear, permanent pressure-sensitive adhesive. Designed to protect and prolong the life of printed images, Series 3420 is made of a polymeric facestock and available in gloss, satin and matte finishes. Series 3420 is rated for outdoor durability up to 5 years.

Recommended Applications:

- Promotional Graphics
- Short-Term Signage
- Kiosks
- POP Display

	SKU	SIZE
	3420-3015-100	30"X50YD
	3420-4815-100	48"X50YD
	3420-5415-100	54"X50YD
	3420-3015-000	30"X50YD
	3420-5415-000	54"X50YD



Wrap Kit Available!
3420-KIT30-GLS
3420-KIT48-GLS
3420-KIT54-GLS
3420-KIT30-SAT
3420-KIT54-SAT



Arlon 3510 3.2 mil • 3 Year • Intermediate Calendered Overlaminates

Partial Wrap ✓

Clear Solvent Adhesive

Arlon 3510 is a 3.2-mil (80 micron) calendered film with a clear, permanent pressure-sensitive adhesive. Designed to protect your printed image, Series 3510 is made of a monomeric facestock and available in a gloss or matte finish.

Recommended Applications:

- Short-Term Signage
- Kiosks
- POP Displays

	SKU	SIZE
	3510-54-G	54" X 50YD
	3510-54-M	54" X 50YD NEW



ORACAL Oraguard 210 2.5 mil • 4 Year • PVC Laminating Film

Partial Wrap ✓

Clear Solvent Adhesive

Oraguard 210 is a 4-year, 2.5-mil laminating film, provides solid protection for digital prints in short- to medium-term indoor and outdoor applications. Recommended for cold lamination. Provides a UV extension factor of 2 years for your outdoor prints. Available in gloss, semi-gloss, and matte finishes.

Recommended Applications:

- Vehicle Wraps
- Vehicle Graphics
- Window Graphics

	SKU	SIZE
	3-8957-5430	54" X 10YD

Guaranteed to offer the lowest price to our loyal customers

ORACAL *Oraguard 215 2.75 mil • 5 Year • PVC Laminating Film*

Partial Wrap ✓

Clear Solvent Adhesive

Oraguard 215 is a durable 5-year, 2.75-mil laminating film has been specially manufactured to protect digital prints used in outdoor and backlit signage. ORAGUARD® 215 film is recommended for cold lamination. Provides a UV extension factor of 3 years for your outdoor prints. Available in gloss, semi-gloss, and matte finishes.

Recommended Applications:

- Protection of Medium to Long-Term Indoor/Outdoor Digital Print
- Vehicle Graphics
- Flat application ONLY

SKU

SIZE

215-30-G	30" X 50YD
215-54-G	54" X 50YD



ARLON

DPF 4500 G 3.0 mil • 5 Year • Printable Overlaminates & Media Digital Film

Eco-Solvent ✓ Solvent ✓ Latex ✓ UV ✓

Clear Solvent Adhesive

DPF 4500G Clear is a 3-Mil (75 micron) clear calendered film with permanent pressure-sensitive adhesive. Designed for indoor and outdoor promotional graphics, DPF 4500G Clear is made of intermediate calendered face stock with a poly coated liner. The special face stock is designed for applications requiring high gloss or flat matte finish. DPF 4500G Clear is rated for outdoor durability up to 5 years (unprinted). Printed durability is dependent on the ink system used.

Recommended Applications:

- POP Displays
- Second Surface
- Windows
- Medium-Term Graphics

SKU

SIZE

4045-3015-100	30" X 50YD
4045-5415-100	54" X 50YD



Overlaminates makes the graphic film thicker which makes it easier to handle and reposition without destroying the image!

Guaranteed to offer the lowest price to our loyal customers





DPF 207 6.0 mil • 1 Year • Removable Decoration Vinyl

Removable ✓ Eco-Solvent ✓ Solvent ✓ UV ✓

Clear Solvent Adhesive

DPF 207 is a 6-mil (150 micron) matte white vinyl film with a clear removable pressure-sensitive adhesive. The adhesive is specially designed to have initial repositionability to substrates such as smooth painted non-vinyl walls without compromising the ultimate bond. DPF 207 has a premium moisture stable polycoated lay-flat liner that is optimal for printing on a variety of print systems.

Recommended Applications:

- Indoor Advertising
- Tradeshow Graphics
- Retail Displays
- POP Display
- Home Decor

SKU

SIZE

4207-5415-202

54" X 50YD



DPF 206 6.0 mil • 1 Year • Removable Coated Wall Fabric

Removable ✓ Eco-Solvent ✓ Solvent ✓ UV ✓

Clear Solvent Adhesive

DPF 206 is a 6-mil (150 micron) light weight polycoated matte white fabric with a unique woven texture. The clear removable pressure sensitive adhesive is designed to bond well to substrates such as smooth painted non-vinyl walls. DPF 206 has a lay-flat liner that is optimal for printing on a variety of print systems. This is the ideal film for wall decorations that require ease of application as well as removability.

Recommended Applications:

- Indoor Advertising
- Tradeshow Graphics
- Retail Displays
- POP Display
- Home Decor

SKU

SIZE

4206-5410-202

54" X 100FT



Orajet 3620 3.0 mil • 4 Year • Transparent PVC Window Graphics Digital Media

Removable ✓ Eco-Solvent ✓ Solvent ✓ Latex ✓ UV ✓

Water Based Adhesive

Oranguard 210 is a 3-mil, 4-year transparent film is typically used for window signage and other shorter-term promotional applications. Features a clear water-based removable adhesive. Suitable for indoor or outdoor flat-surface applications where you want the printed image to "float." Available in transparent gloss and matte finishes.

Recommended Applications:

- Storefronts
- POP Retail
- Window Graphics

SKU

SIZE

3620-30-G

30" X 50YD

3620-54-G

54" X 50YD



Guaranteed to offer the lowest price to our loyal customers



RITRAMA 3-2287 6.0 mil • 2 Year • Window Perforated Exterior Surface Application

Removable ✓ Eco-Solvent ✓ Solvent ✓ Latex ✓

Clear Solvent Adhesive

3-2287 is a matte white vinyl laminated onto black vinyl and perforated (this version has 40% open area -1.5-mm holes) in order to print on one side and to see through the other side. The semi-permanent acrylic adhesive is repositionable and easy to remove after application. Printing methods: solvent and UV screen printing

Recommended Applications:

- Outdoor and transit advertising
- Point of purchase displays
- Novelty products
- Window glazing (buses, trams fleet in general)

SKU	SIZE
3-2287-5433	54" X 33FT

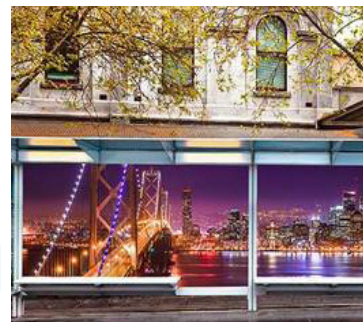

ORACAL Orajet 3850 3.0 mil • 7 Year • Translucent Calendered Digital Media

Eco-Solvent ✓ Solvent ✓ Latex ✓ UV ✓

Clear Solvent Adhesive

Orajet 3850 is high-performance, 3-mil, 7-year translucent inkjet media is excellent for producing brilliant backlit signage, both indoors and out. ORAJET® 3850 features a semi-gloss finish for reduced glare and a clear, permanent adhesive for internally illuminated applications that last. Recommended for use with ORAGUARD® 215, 240, 290, 290GF, 293 and 297GF laminating films.

Recommended Applications:

- Long-Term use on rigid substrates in backlit Indoor/Outdoor Applications

SKU	SIZE
3850-30	30" X 50YD
3850-54	54" X 50YD



DPF 210 9.8 mil • 1 Year • Premium, Semi -Rigid, Polyester Coated Banner

Eco-Solvent ✓ Solvent ✓

Clear Solvent Adhesive

DPF 210 is a premium, semi-rigid, coated polyester banner that is used in roll-up or pop-up banner applications. It has a gray, block-out layer that provides excellent opacity. DPF 210 is available in satin texture finish and yields high print resolution and image quality. It also has excellent lay-flat properties with minimal edge-curl. DPF 210 is compatible with Eco-Solvent, Solvent or LatexQ inks

Recommended Applications:

- Indoor Advertising
- Tradeshow Displays
- Roll Up Displays
- POP Display

SKU	SIZE
4210-3603-002	36" X 32.8YD
4210-5003-002	50" X 32.8YD NEW



Guaranteed to offer the lowest price to our loyal customers

Fdc **FDC 7270** 3.2 mil • 5 Year • Intermediate Grade Calendered Translucent Vinyl



Eco-Solvent ✓ Solvent ✓ Latex ✓ UV ✓

Clear Solvent Adhesive

FDC 7270 is an intermediate grade calendered translucent vinyl film designed for printing backlit graphics and signage requiring medium-term durability.

Recommended Applications:

- Backlit Graphics
- Signage requiring medium-term durability

SKU	SIZE
7270-5415-049	54" X 50YD



Fdc **FDC 7521Mesh** 3.2 mil • 5 Year • Intermediate Grade Calendered Translucent Vinyl



Eco-Solvent ✓ Solvent ✓ Latex ✓ UV ✓

N/A

FDC 7521 is a matte white polyester mesh banner material is 8 oz and 100% adhesive. It is Eco-solvent, Solvent, UV and Latex ink compatible.

Recommended Applications:

- Merchandising
- Advertising
- Building Wraps

SKU	SIZE
7521-54-MESH	54" X 40YD



ARLON

DPF 6500 2 mil • 7 Year • Premium Translucent Cast Film

Repositionable ✓ Air-Release ✓ Eco-Solvent ✓ Solvent ✓ Latex ✓ UV ✓

Clear Solvent Adhesive

DPF 6500 is a 2-mil (50 micron) gloss white, cast, translucent film with a permanent pressure-sensitive adhesive. Designed for backlit graphics, DPF 6500 is made of a premium cast facestock with a special lay-flat liner. The film provides superior print resolution and image quality.

Recommended Applications:

- Windows
- Second Surface Signs

SKU	SIZE
4065-3015-020	30" X 50YD
4065-5406-020	54" X 20YD



Guaranteed to offer the lowest price to our loyal customers

EconoMag Printable Magnetic Material

ECONOMAG

Eco-Solvent ✓ Solvent ✓ Latex ✓ UV ✓

Clear Solvent Adhesive

Choose from several different lengths, widths, thicknesses and surface laminations. Available with or without adhesive, or white vinyl. Can be cut to length, scored or cut through the magnet to the liner.

Compatible Inks:

- UV • Solvent • Eco-Solvent

SKU	SIZE
MAG24X25X030*	24" X 25FT
MAG40X50X030*	40" X 50FT
MAG40X50x020**	40" X 50FT

* 30 Mil **20 Mil

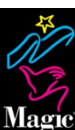

Stick2 7 mil • Polypropylene, Low Tack Removable, Repositionable & Re-Apply

Removable ✓ Aqueous ✓ Eco-Solvent ✓ Solvent ✓ UV ✓

Clear Solvent Adhesive

Stick2 is a 7 mil repositionable banner with a low tack, pressure sensitive adhesive that is repositionable, removable, and may be reapplied to some surfaces. Has a universal coating that is compatible with most water-based thermal and piezo as well as solvent and eco-solvent wide format printers. can be used indoors and outdoors for both short and long-term signage.

Recommended Applications:

- Posters
- Displays
- Window & Wall Coverings
- Trade Show

SKU	SIZE
STICK2-30	36" X 100FT

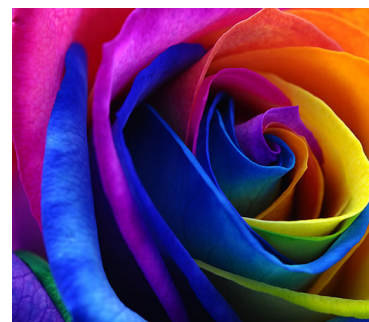

ARLON

DPF 8000 3.5 mil • 7 Year • Industrial Grade Film for Hard-to-Stick Surfaces

Eco-Solvent ✓ Solvent ✓ Latex ✓ UV ✓

Clear Solvent Adhesive

DPF 8000 is a satin white, high-tensile, PVC film with aggressive, permanent pressure-sensitive adhesive. Designed for indoor and outdoor graphics, DPF 8000 White is made of a 100% engineering-grade facestock with a polycoated lay-flat liner. The special adhesive system is designed to stick to "hard-to-stick" and low-energy surfaces such as brick, concrete and stucco walls, and ABS plastic. DPF 8000 White is designed to meet the marking requirements and specifications of the transportation, vending and automotive industries.

Recommended Applications:

- Wall Murals
- ABS Plastics
- Rough Surfaces
- Brick, Concrete & Stucco

SKU	SIZE
4087-3015-002	30"X50YD
4087-5415-002	54"X50YD

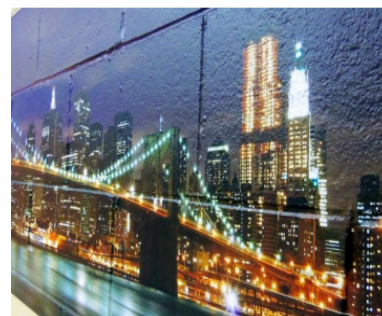

Guaranteed to offer the lowest price to our loyal customers



Eco-Satin 8.5 mil • Coated 1 side Printable White, Promotional

Eco-Solvent ✓ Solvent ✓ Latex ✓ UV ✓

Eco-Satin is an 8.5 Mil satin paper for solvent, eco solvent, UV cure and latex inks. Eco-Satin is a cost effective option for posters, back-lit and POS applications. This product is also Recyclable.

Recommended Applications:

- Indoor Use
- Posters
- POP Displays
- Signage

SKU	SIZE
ECOSATIN-30	30" X 150FT
ECOSATIN-54	54" X 150FT



GFIOP212 9.9 mil • Heavy Weight, Coated 1 side, wet-strength, High Resolution

Aqueous ✓ Eco-Solvent ✓ Solvent ✓ Latex ✓ UV ✓

GFIOP212 is a 9.9 mil latex-saturated, wet-strength paper for indoor banners, outdoor posters and wallcoverings. One-side coated paper designed to meet the demands of high production solvent and eco-solvent ink jet printers. This latex-saturated, wet strength paper features a smooth surface which offers exceptional print fidelity with a distinctive luster finish. Strength, flexibility and durability are hallmark traits of GFIOP. It resists cracking when folded, and film lamination is not required in most intended applications.

Recommended Applications:

- Indoor/Outdoor Short Term Use
- Wall Coverings
- Posters
- Promo Signage

SKU	SIZE
GFIOP212-54	54" X 150FT



GF Photo 7 mil • Light Weight Photo, Realistic, High Resolution

Eco-Solvent ✓ Solvent ✓ Latex ✓ UV ✓

GF Photo is a premium satin photorealistic paper specifically designed for solvent, eco-solvent, latex, and UV cure printers. Indoor use unless encapsulated with a safe edge

Recommended Applications:

- Posters
- Displays
- Window & Wall Coverings
- Trade Show

SKU	SIZE
GFPHOTO-54	54" X 100FT



Guaranteed to offer the lowest price to our loyal customers



GF Photo 240 10 mil • Heavy Weight Photo, Realistic, High Resolution

Eco-Solvent ✓ Solvent ✓ Latex ✓ UV ✓

GF Photo 240 is a unique, durable heavy weight photographic paper for solvent inkjet printers. It is ideal for photographic, portrait and fine art reproductions as well as suitable for posters, maps and display graphics that may require more stiffness and durability.

Recommended Applications:

- Fine Art
- Indoor Use
- Window Photo Portrait

SKU

GFPHOTO-240-54

SIZE

50" X 100FT



BANNERS



DPF 313 13 oz • 1 Year • White Polyester Scrim - 1 Side

Eco-Solvent ✓ Solvent ✓ Latex ✓ UV ✓

Opacity: >95%

DPF 313 is a frontlit 13-oz white, scrim PVC banner. Available in matte and high gloss, both finishes are smooth and yield high print resolution and image quality. It is a multi-purpose banner suitable for digital printing, screen printing and adhesive-backed vinyl application. DPF 313 is enhanced with 1000 Denier scrim giving the product greater tear and curl resistance. Furthermore, DPF 313 passes the NFPA 701 fire resistant certification test.

Recommended Use:

- Billboard (1000D)
- Indoor and Outdoor
- Merchandising and Display Graphics
- Short-Term Banner
- Tradeshow Displays Graphics
- POP Displays

SKU	SIZE
DPF313-30X40GLS	30" X 40YD
DPF313-38-X40GLS	38" X 40YD
DPF313-48-X40GLS	48" X 40YD
DPF313-54-X40GLS	54" X 40YD
DPF313-63-X40GLS	63" X 40YD
DPF313-30X40MAT	30" X 40YD
DPF313-38X40MAT	38" X 40YD
DPF313-48X40MAT	48" X 40YD
DPF313-54X40MAT	54" X 40YD
DPF313-63X40MAT	63" X 40YD



DPF 315 15 oz • 1 Year • White Polyester Scrim - 2 Side

Eco-Solvent ✓ Solvent ✓ Latex ✓ UV ✓

Opacity: Blockout - 100%

DPF 315 is a high quality, economical 15-oz white, scrim PVC banner with blockout. Available in matte and high gloss, both finishes are smooth and yield high print resolution and image quality. The blockout provides opacity for dual side printing. Matte is recommended for dual side printing due to the similar finish on both sides. It is a multipurpose banner –suitable for digital printing and adhesive-backed vinyl application. DPF 315 is designed to be both tear and curl resistant. Furthermore, DPF 315 passes the NFPA 701 fire resistant certification test.

Recommended Use:

- Billboard
- Indoor and Outdoor
- Merchandising and Display Graphics
- Indoor Hanging
- Graphics

SKU	SIZE
DPF315-38-GLOSS	38" X 50YD
DPF315-54-GLOSS	54" X 50YD
DPF315-62-GLOSS	62" X 50YD
DPF315-38-MATTE	38" X 50YD
DPF315-54-MATTE	54" X 50YD
DPF315-62-MATTE	62" X 50YD



Guaranteed to offer the lowest price to our loyal customers



ARLON

DPF 303 13 oz • 1 Year • White Polyester Scrim - 2 Sided

Eco-Solvent ✓ Solvent ✓ Latex ✓ UV ✓

Opacity: Blockout - 100%

DPF 303 is a 13-oz white, super smooth, scrim PVC banner with blockout features. This calendared vinyl provides superior print resolution and image quality on both sides of the banner. The scrim is undetectable, whether it is printed or unprinted. This banner is excellent for graphics that will be viewed at a close distance.

Recommended Use:

- Merchandising
- Displays
- High-Res Graphics

SKU

DPF303-38-SATIN

DPF303-54-SATIN

SIZE

38" X 50YD

54" X 50YD



7521 Mesh 8 oz • 1 Year • White Polyester Mesh - 1 Sided

Eco-Solvent ✓ Solvent ✓ Latex ✓ UV ✓

Opacity: 100%

7521 Mesh is an 8 oz. mesh PVC banner designed for printing general purpose signage and displays. It features a PVC liner on the back side to be removed after printing and a 63% surface area with 37% air flow.

Recommended Use:

- Indoor
- Merchandising
- Film
- TV
- Theater
- Outdoor Advertising
- Building Wraps

SKU

7521-54-MESH

SIZE

54" X 40YD



ARLON

DPF 390 19.5 oz • 1 Year • Heavy Weight White Media - Durable Flex

Eco-Solvent ✓ Solvent ✓ Latex ✓ UV ✓

Opacity: >75

DPF 390 is a high-quality, intermediate backlit 19.5-oz white flexible substrate. It is designed for any backlit illuminated indoor or outdoor signage. DPF 390 can be decorated with translucent pressure-sensitive vinyl film or printed on with a wide variety of printers using Eco-Solvent, Solvent, UV and Latex inks. The heavy weight, durable flexible substrate is both tear and curl resistant, and it is RF weldable. It is compatible with various tensioning systems. DPF 390 has an anti-fungus and anti-wicking treatment.

Recommended Use:

- Back Illuminated Signs
- Awnings
- LED or Fluorescent Light Boxes

SKU

DPF390-4'-164

DPF390-6'-164

DPF390-8'-164

DPF390-12'-164

SIZE

4'6" X 164'

6'6" X 164'

8'6" X 164'

12'6" X 164'



Guaranteed to offer the lowest price to our loyal customers



ARLON

DPF 210 9.8 mil • 1 Year • Premium, Semi-Rigid, Polyester Coated Banner

Eco-Solvent ✓ Solvent ✓

Opacity: 95%

DPF 210 is a premium, semi-rigid, coated polyester banner that is used in roll-up or pop-up banner applications. It has a gray, block-out layer that provides excellent opacity. DPF 210 is available in satin texture finish and yields high print resolution and image quality. It also has excellent lay-flat properties with minimal edge-curl. DPF 210 is compatible with Eco-Solvent, Solvent or LatexQ inks

Recommended Use:

- Indoor Advertising
- Tradeshow Displays
- Roll Up Displays
- POP Display

SKU

SIZE

4210-3603-002	36" X 32.8YD
4210-5003-002	50" X 32.8YD NEW



Top Value 13 Super 13 oz • Super Smooth Vinyl 2-Sided

Eco-Solvent ✓ Solvent ✓ Latex ✓ UV ✓

Opacity: Blockout - 100%

13 Super is the perfect choice for all indoor double sided printed banner or display graphics applications. This reinforced laminated vinyl banner material is manufactured with a blockout polyester support cloth center and PVC laminated to the top and bottom, and is engineered as an economical choice for short-term special event banners or high-end interior POP displays.

Recommended Use:

- Indoor/Short Tem
- Outdoor Application

SKU

SIZE

130Z38SUPSMOOTH	38" X 50YD
130Z54SUPSMOOTH	54" X 50YD



Top Value 18 Super 18 oz • Super Smooth Vinyl 2-Sided

Eco-Solvent ✓ Solvent ✓ Latex ✓ UV ✓

Opacity: Blockout - 100%

18 Super is the best choice for long-term outdoor pole banners or double sided banners when there is exposure to severe conditions. The super smooth finish and superior lay flat quality help make this media ideal for use in high-end display applications or for close viewing distances. This reinforced laminated vinyl banner material is manufactured with extremely strong blockout polyester scrim and is stocked in numerous widths and lengths.

Recommended Use:

- Indoor/Short Tem
- Outdoor Application

SKU

SIZE

180Z38SMOOTH	38" X 50YD
180Z54SMOOTH	54" X 50YD



Guaranteed to offer the lowest price to our loyal customers





Top Value 13 Standard Banner 13 oz • White Polyester Scrim 1-Sided

Eco-Solvent ✓ Solvent ✓ Latex ✓ UV ✓

Opacity: Blockout - 100%

13 Standard Banner is a 13oz standard Banner Material has white polyester scrim, is 1-sided and is 100% block out. The recommended use is indoor or long-term outdoor applications. It is Eco-Solvent, Solvent, Latex and UV Printable! The Standard banner material comes in Matte White and is 54"x40YD.

Recommended Use:

- Indoor/Short Tem
- Outdoor Application

SKU

13OZ54STAND

SIZE

54" X 40YD



Top Value 3 Flag 3 oz • Flag & Skirt 1-Sided

Eco-Solvent ✓ Solvent ✓ UV ✓

3 Flag is engineered to provide a superior media platform for flag manufacturers requiring Solvent, Eco-Solvent or UV ink compatibility. This flag polyester has a removable paper liner to make printing and feeding the media through the machine as easy as possible for a smooth printing experience.

Recommended Use:

- Short Term Outdoor/
- Long Term Indoor

SKU

3OZ54STAND

SIZE

54" X 100FT



Guaranteed to offer the lowest price to our loyal customers



PRINTABLE HEAT TRANSFER VINYL



CADdigital PU 85 mic • Print and CUt Material in a Matte Finish

Eco-Solvent ✓ Solvent ✓ Latex ✓

CADdigital PU is affordable, thin, and soft! If you're looking to create full-color graphics on garments with your Eco-Solvent, Solvent or Latex based printer/cutter, CADdigital™ PU just might be the answer! Holds color exceptionally well, soft to the touch and safe for decorating children's items! CADdigital™ PU is great because it's simple to use! Print, cut, mask, and press! It's that simple to use.

Recommended Application:

- 100% Cotton
- 100% Uncoated Polyester
- Poly/Cotton Blends
- Leather

SKU	SIZE
CDIGS2027-5Y	20" X 5YD



CADdigital PVC 85 mic • Print and Cut Material with PVC Base, Polyester Backing

Eco-Solvent ✓ Solvent ✓ Latex ✓

CADdigital PVC uses your Eco-Solvent, Solvent or Latex based printer/cutter to print and cut brilliant full-color logos, designs or unique team name / number sets. CADdigital™ PVC is durable and has a semi-gloss finish; it's also simple to use! Print, cut, mask, and press!

Recommended Application:

- 100% Cotton
- 100% Uncoated Polyester
- Poly/Cotton Blends
- Leather

SKU	SIZE
CDIG2027	20" X 27YD



ColorPrint PU 70 mic • Stretchable Print/Cut Material with PU Composition, Polyester Backing

Eco-Solvent ✓ Solvent ✓

ColorPrint PU is a thin & stretchable print and cut material. Looking to create stretchable full-color graphics from your Eco-Solvent or Solvent based printer/cutter? ColorPrint™ PU is the answer to your needs! It's thin enough to provide a great hand and stretchable enough for most performance wear. ColorPrint™ PU is great because it doesn't require any dry time before masking.

Recommended Application:

- 100% Cotton
- 100% Uncoated Polyester
- Poly/Cotton Blends
- Lycra/Spandex

SKU	SIZE
CPPU2955401-25Y	29.5" X 25YD
CPPU205401-25Y	20" X 25YD



Guaranteed to offer the lowest price to our loyal customers



Results™ Dye Block 100 mic • Printable Vinyl for Dye Sublimated Fabrics

Eco-Solvent ✓ Solvent ✓ Latex ✓ UV ✓

Dye Block is PRINT SMART TECHNOLOGY™. Print vibrant color custom graphics with photographic quality. Print, Cut, weed, mask, then transfer in 8-12 seconds. Keeps an ultra-soft feel, emulates screen printing without cracking or peeling from any fabric. Durable, flexible at just 100 Microns, superior abrasive, waterproof, stain resistant, and made for aggressive wear and play.

Recommended Application:

- 100% Cotton
- 100% Uncoated Polyester
- Poly/Cotton Blends
- Leather

SKU	SIZE
TDF-PDB-5M	20" X 5.5YD
TDF-PDB-10M	20" X 11YD
TDF-PDB-30M	20" X 33YD



Results™ White Opaque 75 mic • Printable Vinyl film for Dark and Light

Eco-Solvent ✓ Solvent ✓ Latex ✓ UV ✓

Results White Opaque is the only printable All-Fabric heat transfer film you will ever need. Print, trim, transfer in minutes. One-offs or thousands. Ultra soft hand fee, Multi-layer, and sew-able. Unlimited Stretch and rebound. Perfectly comfortable at 75 microns thick. No plastic feeling.

Recommended Application:

- Cotton
- Polyester
- Nylon
- Moisture Wicking
- Lycra
- Spandex
- Paper
- Cardboard
- Leather
- Heat Sensitive

SKU	SIZE
TDF-1011M-10M	20" X 11YD
TDF-1011M-30M	20" X 33YD



Guaranteed to offer the lowest price to our loyal customers

REFLECTIVE FILM



ARLON

DPF 2400 5.0 mil • 7 year • Fleet Grade Digitally Printable Reflective Film

Partial Wrap ✓ Eco-Solvent ✓ Solvent ✓ UV ✓

Clear Solvent Adhesive

DPF 2400 is a 5-mil (125 micron) printable reflective vinyl film with high initial tack and permanent pressure-sensitive adhesive. The film conforms well to both flat and irregular surfaces when processed and applied according to Arlon recommendations. DPF 2400 meets or exceeds the following standards for motor vehicles: ISO 7591-1982, DOT FP-85 - Section 718, Federal Spec. L-S-300C, and ASTM-D 4956-89, Spec. Type 1, Class 1.

Recommended Application:

- Vehicle Graphics
- Decals
- Fleet Markings

SKU	SIZE
2400-483-222	48.5" X 10YD
2400-4815-222	48.5" X 50YD



Oralite 5600 5.0 mil • 7 year • Fleet Engineer Grade Digitally Printable Reflective Film

Removable ✓ Eco-Solvent ✓ Solvent ✓ Latex ✓ UV ✓

Clear Solvent Adhesive

Oralite 5600 is flexible, printable reflective film is the perfect choice for emergency vehicle graphics and other applications where a durable, conformable and removable* reflective film is required. Solvent inkjet and thermal-print compatible, this innovative reflective film provides endless creative options. *Removable with heat.

Recommended Application:

- Vehicle Graphics
- Reflective Lettering
- Fleet Markings
- Decorations

SKU	SIZE
5600-15-XXX	15" X 50YD
5600-24-XXX	24" X 50YD
5600-XX-XXX	30" X 10Y/50Y
5600-XX-XXX	48" X 10Y/50Y
5600-XX-XXX	54" X 10Y/50Y
5600-603-XXX	60" X 10YD



Oralite 5650RA 4.3 - 5.5 mil • 7 year • Fleet Engineer Grade Digitally Printable Reflective Film

Repositional ✓ Air-Release ✓ Removable ✓ Eco-Solvent ✓ Solvent ✓ Latex ✓ UV ✓

Clear Solvent Adhesive

Oralite 5650RA is a premium reflective film engineered specifically for challenging fleet applications. These reflective films reflect light in low-light and nighttime applications and are generally used in municipal signage. Oralite 5650RA is a 5.5 mil film that's compatible with digital solvent and eco-solvent printers, and produces sharp crisp images suitable for commercial vehicle wraps and digitally printed municipal fleet graphics for police, fire, and other emergency vehicles. Application is made easier by the use of ORACAL's Rapid Air air egress liner which allows trapped air to escape during installation.

Recommended Application:

- Fleet Applications

SKU	SIZE
5650RA-XXX-G	15" X 10Y/50Y
	30" X 10Y/50Y
	48" X 10Y/50Y
	54" X 10Y/50Y



RapidAirTM
AIR RELEASE SYSTEM

Guaranteed to offer the lowest price to our loyal customers



www.nepcosignsupply.com

32

800-327-7562 | sales fax 401-438-1533



M8500 Series 5.34 mil • 7 year • Fleet Marking Grade Retroflective

Eco-Solvent ✓ Solvent ✓ Latex ✓

Acrylic Permanent Adhesive

M8500 Series is a product manufactured for use as fleet marking, vehicle markings, sticker, decal, etc. which can be either digital-printed or screen-printed with multi-colored inks that will adhere very well to this sheeting. Coated with a pressure sensitive adhesive protected with an easily removable liner, this sheeting is easy to handle because of its great flexibility and is capable of giving high retroreflectivity, even when totally wet.

Recommended Application:

- Traffic Signs
- Barricades
- Delineation Devices
- Conspicuity Marking
- Decals
- Banners & Fleet Marking

SKU	SIZE
M8512-3010	30" X 10YD
M8512-3050	30" X 50YD
M8512-4810	48" X 10YD
M8512-4850	48" X 50YD



48000 Series 4.83 mil • 7 year • Flexible Engineering Grade Retroflective Sheeting

Eco-Solvent ✓ Solvent ✓ Latex ✓

Pressure Sensitive Adhesive

48000 Series is a product manufactured for use as fleet markings, vehicle markings, stickers, decals, etc. which can be screened with multi-colored inks that will adhere very well to this sheeting. flexible, printable reflective film is the perfect choice for emergency vehicle graphics and other applications where a durable, conformable and removable reflective film is required. *Removable with heat.

Recommended Application:

- Commercial Signs
- Decals
- Fleet Marking
- Vehicles

SKU	SIZE
4800XX/XXXX	15" X 10/50YD
	24" X 10/50YD
	30" X 10/50YD



Guaranteed to offer the lowest price to our loyal customers



ARLON

DPF 210 9.8 mil • 1 Year • Premium, Semi -Rigid, Polyester Coated Banner

Eco-Solvent ✓ Solvent ✓

Opacity: 95%

DPF 210 is a premium, semi-rigid, coated polyester banner that is used in roll-up or pop-up banner applications. It has a gray, block-out layer that provides excellent opacity. DPF 210 is available in satin texture finish and yields high print resolution and image quality. It also has excellent lay-flat properties with minimal edge-curl. DPF 210 is compatible with Eco-Solvent, Solvent or LatexQ inks

Recommended Use:

- Indoor Advertising
- Tradeshow Displays
- Roll Up Displays
- POP Display

SKU

SIZE

4210-3603-002

36" X 32.8YD

4210-5003-002

50" X 32.8YD **NEW**



Guaranteed to offer the lowest price to our loyal customers



www.nepcosignsupply.com

34

800-327-7562 | sales fax 401-438-1533



GFCVM 15 mil • Artist Stretch Canvas.

Eco-Solvent ✓ Solvent ✓ Latex ✓

GFCVM is a 15 mil acid free, matte finish, polyester/cotton blend, artist stretch inkjet canvas with a special coating, which produces superior color gamut and resolution. Designed for high volume production and stretching applications such as photos/portraits, fine art reproductions, photo displays, maps and banners.

Recommended Use:

- Fine Art Reproduction
- Museum Art
- Portrait
- Banner

SKU	SIZE
GFCVM-30	30" X 40FT
GFCVM-50	50" X 75FT
GFCVM-54	54" X 75FT
GFCVM-60	60" X 75FT



HIGH PERFORMANCE VINYL



2100/2200 Series 2 mil • 10 Year • High Gloss Premium Cast Perforated Vinyl

2100/2200 Series is a 2-mil (50 micron) cast film is extra formable, thereby providing exceptional conformability, even on deep recesses and channel constructions on vans. The advanced adhesive system is designed to perform well on a wide variety of substrates including rigid sign faces, banners, and painted metal. With outdoor durability up to 10 years**, it withstands adverse climate and environmental conditions.

Recommended Application:

- Rigid Sign Surfaces • Banners • Painted Metal



Colors and Sizes vary (Please Call for Availability)

	27 Fawn		12 Burgundy		250 Intense Blue		280 Terra Cotta		81 Titanium
	67 Primrose Yellow		39 Burgundy Metallic		37 Medium Blue Metallic		85 Cocoa		28 Dove Gray
	06 Yellow		76 Magenta		05 Blue		08 Brown		80 Graphite
	165 Chrome Yellow		58 Dark Magenta		17 Sapphire Blue		79 Kiwi		50 Medium Gray
	97 Light Orange		56 Hot Pink		66 Medium Blue		69 Apple Green		07 Silver Metallic
	83 Bright Orange		75 Lavender		30 Dark Blue Metallic		61 Kelly Green		21 Smoke Metallic
	96 Tangerine		74 Royal Purple		93 Light Navy		106 Medium Green		52 Dark Gray
	73 Poppy		99 Bright Purple		65 Midnight Blue		24 Dark Green		23 Charcoal Metallic
	220 Perfect Match Red		62 Purple		11 Dark Blue		86 Forest Green		40 Matte Black
	223 Peacock Red		92 Wedgewood Blue		120 Pearl		230 Bottle Green		03 Black
	14 Tomato Red		51 Aruba Blue		26 Oyster		87 Aqua Green		02 White
	221 Geranium		31 Ocean Blue		68 Beige		89 Aqua Blue		00 Clear
	60 Bright Cardinal Red		18 Olympic Blue		04 Gold Metallic		71 Teal		
	42 Cardinal Red		166 Periwinkle		59 Imitation Gold		53 Dark Bahama Blue		
	01 Red		32 Azure Blue		70 Palm Oyster Gray				

*Actual colors may very slightly from examples shown due to limitations in the printing process.



2900/2950 Series 3.5 mil • CalMask White Vinyl

2900/2950 Series is a 3.5 mil (90 micron), a specially formulated white vinyl with a low tack, low shear, and clean removing acrylic adhesive. It also offers an excellent resistance to heat and humidity and a very good resistance to UV.

Recommended Application:

- Sign Faces • Metal Surfaces • Cars • Trucks • Flat or Curved Surfaces

SKU	SIZE	
2900-2415-02	24" X 50YD	UNPUNCHED
2900-243-02	24" X 10YD	UNPUNCHED
2900-4815-02	18" X 50YD	UNPUNCHED
2950-1515-02	15" X 50YD	PUNCHED
2950-153-02	15" X 10YD	PUNCHED
2950-3015-02	30" X 50YD	PUNCHED



Arlon 3210 1.3 mil • 7 Year • Premium Cast Overlaminates Pressure-Sensitive Film

Full/Partial Wrap ✓

Clear Solvent Adhesive

Arlon 3210 is constructed of a 1.3-mil (35 micron) gloss cast vinyl film with clear, permanent pressure-sensitive adhesive. Designed to protect printed images and prolong the life of the printed images. Series 3210 provides the same protection as our standard overlaminates while having excellent conformability during installation with a lighter weight film. The gloss finish provides an extra pop to printed graphics.

Recommended Applications:

- Vehicle Wraps
- Fleet Graphics
- Building Wraps
- Long-Term Signage

SKU	SIZE
3210-5415-000	54" X 50YD



Wrap Kit Available!
3210-KIT54-GLS

HIGH PERFORMANCE VINYL

ORACAL 751 2 mil • 7 Year • High Performance High Gloss Vinyl

751 is a 2-mil, high performance PVC film with excellent dimensional stability and very good cutting and application characteristics. Available in 78 vivid colors plus transparent, matte white and matte black.

Recommended Application:

- Rigid Sign Surfaces • Banners • Painted Metal



Colors (Please Call for Availability)

020 Golden Yellow	219 Yolk Yellow	203 Straw Yellow	211 Sun Yellow	019 Signal Yellow	208 Post Office Yellow	517 Euro Blue	053 Light Blue	056 Ice Blue	549 Dove Blue	608 Petrol	054 Turquoise
209 Maize Yellow	021 Yellow	216 Traffic Yellow	022 Light Yellow	025 Brimstone Yellow	026 Purple Red	055 Mint	599 Pastel Turquoise	060 Dark Green	661 Leaf Green	078 Foliage Green	617 Emerald
361 Apple Red	030 Darkred	348 Scarlet Red	306 Crimson	031 Red	027 Tomato Red	607 Turquoise Green	604 Cactus Green	066 Turquoise Blue	061 Green	068 Grass Green	619 Traffic Green
028 Cardinal Red	325 Middle Red	324 Blood Red	032 Light Red	326 Signal Red	047 Orange Red	602 Light Green	064 Yellow Green	063 Lime-Tree Green	080 Brown	803 Chocolate Brown	828 Earth Brown
033 Red Orange	335 Mars Red	333 Pure Red	034 Orange	332 Deep Orange	035 Pastel Orange	079 Red Brown	083 Nut Brown	801 Loam Brown	811 Sahara Beige	081 Light Brown	818 Saffron
340 Chestnut	048 Bordeaux	415 Summer Plum	040 Violet	403 Light Violet	043 Lavender	804 Beige Brown	023 Cream	813 Light Cream	018 Light Ivory	070 Black	720 Komatsu Grey
042 Lilac	041 Pink	077 Telemagenta	044 Magenta	045 Soft Pink	532 Black Blue	073 Dark Grey	713 Iron Grey	071 Grey	721 Slate Grey	076 Telegrey	074 Middle Grey
588 Alpha Blue	590 Blueberry	518 Steel Blue	591 Midnight Blue	050 Dark Blue	058 Ultramarine Blue	724 Ice Grey	072 Light Grey	109 Hull White	010 White	090 Silver Grey	930 Gold
537 Deep Blue	065 Cobalt Blue	049 King Blue	592 Navy Blue	593 String Blue	150 Brilliant Blue	093 Anthracite	932 Graphite Metallic				
536 Midnight Blue	510 Clematis Blue	067 Blue	595 Blue Green	057 Traffic Blue	051 Gentian Blue						
509 Sea Blue	508 Signal Blue	052 Azure Blue	507 Capri Blue	555 Glacier Blue	594 Pastel Blue						

*Actual colors may vary slightly from examples shown due to limitations in the printing process.



4500 CalPlus 3 mil • 6 Year • Satin Intermediate Vinyl

4500 CalPlus is a 3-mil (75 micron) calendered film that is ideal for a wide variety of applications. This product comes in 28 eye-catching colors and has an outdoor durability of up to 6 years.

Recommended Application:

- Interior/Exterior Graphics • Banners



Colors and Sizes vary (Please Call for Availability)

	168 Daisy Yellow		160 Bright Cardinal Red		137 Blueberry		108 Brown		134 Cloud Gray
	116 Lemon Yellow		173 Dark Red		193 Viking Blue		180 Terra Cotta		149 Light Gray
	106 Yellow		112 Burgundy		130 Dark Blue		159 Imitation Gold		103 Black
	119 Light Orange		110 Purple		171 Teal		182 Beige		102 White
	109 Orange		176 Dark Purple		164 Spring Green		104 Gold Medal		100 Clear
	114 Tomato Red		118 Olympic Blue		111 Green		107 Silver		
	133 Fire Red		198 Medium Blue		135 Imperial Green		150 Dark Gray		
	101 Red		105 Blue		186 Forest Green		140 Gray		

*Actual colors may vary slightly from examples shown due to limitations in the printing process.

INTERMEDIATE VINYL



5000 3 mil • 6 Year • High Gloss Intermediate Vinyl

5000 Series is an ultra thin 2.8-mil (70 micron) calendered film is one of the most pliable calendered films on the market. The product has a high gloss finish, and is ideal for signs, graphics or displays requiring vibrant color. This new film is available in 37 bright colors, provides excellent cutting and weeding for improved productivity and has an outdoor durability rating of up to 6 years.

Recommended Application:

- Interior/Exterior Graphics • Banners



Colors and Sizes vary (*Please Call for Availability*)

	68 Daisy Yellow		31 Rose		71 Teal		04 Gold Medal
	06 Yellow		10 Purple		60 Spring Green		07 Silver
	09 Orange		36 Mission Blue		11 Green		34 Cloud Gray
	33 Fire Red		05 Blue		61 Medium Green		03 Black
	01 Red		37 Blueberry		35 Imperial Green		40 Matte Black
	12 Burgundy		50 Royal Blue		08 Brown		02 White
	32 Cotton Candy		30 Dark Blue		41 Tusk		49 Matte White

*Actual colors may vary slightly from examples shown due to limitations in the printing process.



651 2.5 mil • 6 Year • Intermediate Calendered Vinyl Film

651 is a 2.5-mil, intermediate calendered PVC film with excellent dimensional stability and very good cutting and application characteristics. Available in 60 vivid colors plus transparent, matte white and matte black.

Recommended Application:

- Medium-Term Indoor and Outdoor Lettering • Marking • Decoration



000 Transparent	010 White	020 Golden Yellow	019 Signal Yellow	021 Yellow	022 Light Yellow	025 Brimstone Yellow	026 Purple Red
312 Burgundy	030 Dark Red	031 Red	032 Light Red	047 Orange Red	036 Light Orange	035 Pastel Orange	404 Purple
040 Violet	043 Lavender	042 Lilac	041 Pink	045 Soft Pink	562 Deep Sea Blue	518 Steel Blue	050 Dark Blue
085 Cobalt Blue	049 King Blue	086 Brilliant Blue	067 Blue	057 Traffic Blue	051 Gentian Blue	028 Gentian	052 Azure Blue
084 Sky Blue	053 Light Blue	056 Ice Blue	066 Turquoise Blue	054 Turquoise	055 Mint	060 Dark Green	613 Forest Green
061 Green	068 Grass Green	062 Light Green	064 Yellow Green	063 Lime-Tree Green	080 Brown	083 Nut Brown	081 Light Brown
082 Beige	023 Cream	070 Black	073 Dark Grey	071 Grey	076 Telegrey	074 Middle Grey	072 Light Grey
090 Silver Grey	091 Gold	092 Copper					

*Actual colors may vary slightly from examples shown due to limitations in the printing process.

REFLECTIVE VINYL

48000 6.2 mil • 7 Year • Cut & Apply Series - Flexible Engineering Grade Reflective Vinyl

Nikkalite Nikkalite® Brand 48000 Series Flexible Engineering Grade (ELG) retro-reflective sheeting is a product manufactured for use as fleet markings, vehicle markings, stickers, decals, etc. which can be screened with multi-colored inks that will adhere very well to this sheeting. Coated with a pressure sensitive adhesive protected with an easily removable liner, this white 6.2 mil sheeting is easy to handle because of its great flexibility and is capable of giving high retroreflectivity. 7 years durability.

Recommended Application:

- Commercial Signage • Stickers • Decals • Flat Surfaces • Vehicles



Colors and Sizes vary (*Please Call for Availability*)



48077P
Orange



48004P
Yellow

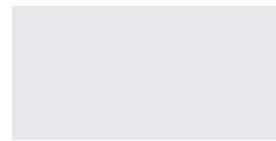

48012P
White



48008P
Green



48046
Sky Bue



48006P
Blue



48005
Red



48035P
Ruby Red



48025P
Dark Red



48010P
Gold



48009P
Brown



48003P
Black

*Actual colors may vary slightly from examples shown due to limitations in the printing process.

ORACAL 5600 5 mil • 7 Year • Fleet Engineer Grade Reflective Vinyl

5600 is a 5 mil, engineering grade, cast PVC, digitally printable reflective film. It is available in 14 high impact colors. Oracal 5600 Reflective comes with a clear solvent-based permanent adhesive and is good for up to 7 years.

Recommended Application:

- Medium-Term Indoor and Outdoor Lettering
- Marking
- Decoration



Colors and Sizes vary (Please Call for Availability)

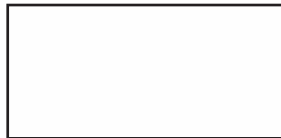

010
White



020
Yellow



030
Red



213
Lemon
Yellow



035
Orange



364
Ruby
Red



054
Turquoise



050
Blue



060
Green



070
Black



080
Brown



091
Gold

*Actual colors may vary slightly from examples shown due to limitations in the printing process.

SPECIALTY VINYL



ARLON

2000 Series 3 mil • 5 Year • High Performance Cast Dazzlers

2000 Series is a premium, super-metallic, 3-mil cast vinyl ideal for high impact signage, striping and logos. Excellent for flat and soft-curved surfaces, this film offers superior release and weeding characteristics. Series 2000 comes in 5 vibrant colors and has up to a 5 year exterior durability.

Recommended Application:

- High Impact Signage • Striping • Logos

Colors and Sizes vary (**Please Call for Availability**)



01
Red



03
Black



04
Gold

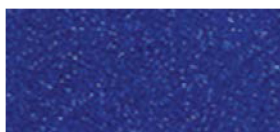

05
Cobalt
Blue

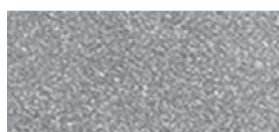

07
Silver



rtape

ChalkTalk 6 mil • Removable Non-Vinyl Chalkboard Film

ChalkTalk™ is a 6 mil non-PVC film coated with a repositionable, removable adhesive. Available in slate gray, its grainy texture provides an exceptional finish for writing and drawing with chalk. ChalkTalk™ is perfect for use as a restaurant menu board or as an appliqué in a home environment. Wipes clean with an eraser, damp towel or sponge.

Recommended Application:

- Restaurant Menu Boards • To-Do Lists • Writable Chalkboard



Sizes vary (**Please Call for Availability**)



Black



DPF 5200 2 mil • 7 Years • Premium Decorative Window Film

DPF 5200 is a premium decorative film that simulates an etched glass finish for interior or exterior applications. Available in three standard finishes, DPF 5200 is an ideal film to transform glass or clear substrates into elegant designs. Further customize graphics by printing on any of the finishes with standard digital print systems. DPF 5200 is the perfect choice for projects where a high-quality film for decorative etched glass designs is required.

Recommended Application:

- Window Graphics • Mirrors • Partitions • Glass or Clear Substrates
- Interior & Exterior Applications

Sizes vary (Please Call for Availability)



314
Etched
Glass



5500 Series 2 mil • 7 Years • Premium Decorative Window Film

DPF 5200 is a premium decorative film that simulates an etched glass finish for interior or exterior applications. Available in three standard finishes, DPF 5200 is an ideal film to transform glass or clear substrates into elegant designs. Further customize graphics by printing on any of the finishes with standard digital print systems. DPF 5200 is the perfect choice for projects where a high-quality film for decorative etched glass designs is required.

Recommended Application:

- Window Graphics • Mirrors • Partitions • Glass or Clear Substrates
- Interior & Exterior Applications

Sizes vary (Please Call for Availability)



314
Etched
Glass



SPECIALTY VINYL

ORACAL 352 1 mil • 1-2 Year • Print Polyester

352 is a transparent, white or metallised polyester film with excellent dimensional stability and good long-term ageing properties. Surface with top-coat for printing. It is optimized for screen and thermal print applications. Applications include decorative labels, name and technical plates, decorations and moldings, and safety stickers. Available in a range of gold and chrome finishes. 2-year outdoor durability.

*Chrome and 2-sided gold-coated colors also available as a 2 mil PETP film.
*Two-sided gold finish features 1-year outdoor durability

Recommended Application:

- Window Graphics • Mirrors • Partitions • Glass or Clear Substrates
- Interior & Exterior Applications



Types and Sizes vary (Please Call for Availability)



Chrome



Gold

ORACAL 383 3.5 mil • 5 Year • Ultraleaf Cast Vinyl Film Perforated/Non-Perforated

383 is a 3.5 mil, 5-year cast film is a cost-effective alternative to 24-carat gold or silver leaf film. ORACAL 383 features a smooth, printable surface and a three-dimensional visual texture. The durable dimensional stability of this film makes it ideal for lettering, marking, and decoration of vehicles, windows, and signs requiring longer-term outdoor durability.

Recommended Application:

- Window Graphics • Mirrors • Partitions • Glass or Clear Substrates
- Interior & Exterior Applications



Types and Sizes vary (Please Call for Availability)



Chrome



Gold

ORACAL **6510 5 mil • Fluorescent Cast Vinyl Film**

65100 is a 4-mil, fluorescent cast PVC film with high visibility when in all daylight conditions. Especially effective in twilight and poor visibility conditions.

Recommended Application:

- Vehicle and Bus Advertising • POP Displays • Labels • Decals • Retail



Colors and Sizes vary (Please Call for Availability)



029
Yellow
Fluorescent



037
Orange
Fluorescent



037
Red Orange
Fluorescent



357
Orange
Fluorescent



039
Red
Fluorescent



046
Pink
Fluorescent



069
Green
Fluorescent

*Actual colors may vary slightly from examples shown due to limitations in the printing process.



Quick Sign Gold 1 mil • 10 • Year 22kt Sign Gold Vinyl Film

Quick 22KT Sign Gold is used around the world to create beautiful graphics indoors and out. 22KT Sign Gold is available in 15" and 24" wide rolls of non-fading 22KT gold vinyl with a permanent pressure sensitive adhesive for use on CAD/CAM sign making systems. Quick 22KT Sign Gold is guaranteed for 10 year outdoor life.

Recommended Application:

- CAD/CAM Sign Making Systems



Types and Sizes vary (Please Call for Availability)

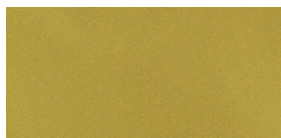

Burnished
Glass

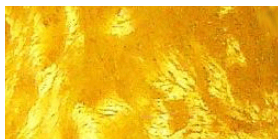

Florentine
Swirl

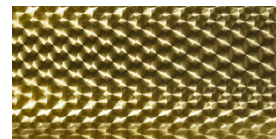

Large Engine
Turn

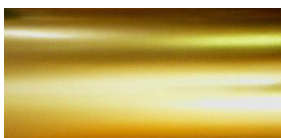

Satin
Surface

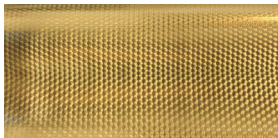

Small Engine
Turn

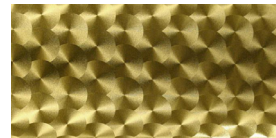

X-Large
Engine
Turn

*Actual colors may vary slightly from examples shown due to limitations in the printing process.



R.tape Vinyl efx 1 mil • 3 Year • Decorative Printable Metallized Vinyl

R.tape Vinyl efx is metallized special effects films have always been popular for decorating racecars, billboards, and short-term promotional signage. The distinctive look of these eye-catching films adds value to their designs, so their signs will command higher selling prices and profits! Vinyl Efx colors are through-and-through the vinyl - NOT laminated or top coated. Unlike cold-embossed polyesters, our fade-resistant films are hot-embossed, which produces deeper, better defined patterns. The Vinyl Efx Outdoor Durable Series, which provides up to three years of outdoor life, is comprised of a variety of cost-effective simulated metal, light-diffracting and 3-D patterns, designed for long-term outdoor signage. For demanding applications such as truck and boat graphics, the Vinyl Efx Durable Series films provide a superior alternative to the expensive simulated gold-leaf films. Available in Gold and Silver.



Recommended Application:

- POP posters • Displays • Vehicle Graphics • Window Graphics • Tradeshow Graphics • Boat

Types, Colors and Sizes vary (*Please Call for Availability*)



1" Large
Engine
Turn



1/4" Small
Engine
Turn



Brushed



Florentine



Hammered
Leaf

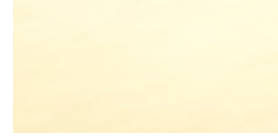

Smooth
Mirror

*Actual colors may vary slightly from examples shown due to limitations in the printing process.



2500 2 mil • 7 Year • Cast Translucent Vinyl Film

2500 Series is a premium 2-mil cast vinyl designed specifically for back or internally illuminated signage. Now with added colors, Series 2500 is available in 58 standard colors, the palette is endless with Arlon's custom color capabilities. Batch-to-batch consistency ensures the integrity of regional and national programs. Series 2500 is compatible with a wide variety of rigid and flexible substrates. All of this is available with a 7 year durability rating.

Recommended Application:

- Interior/Exterior Graphics • Banners



Colors and Sizes vary (*Please Call for Availability*)

	2037 Yellow		43 Light Tomato Red		63 Rust Brown		557 Imperial Blue		3227 Bright Green
	15 Yellow		83 Regal Red		59 Dark Brown		2940 Blue		26 Green
	1090 Yellow		33 Red		69 Duranodic		3238 European Blue		4028 Green
	525 Bright Yellow		2885 Fox Red		22 Black		36 Dark Blue		76 Holy Green
	125 Golden Yellow		2510 Red		57 Olympic Blue		2114 Blue		2108 Green
	25 Sunflower		75 Dark Red		337 Process Blue		87 Royal Blue		112 Olive Green
	169 Marigold		253 Cardinal Red		127 Intense Blue		236 Turquoise		51 Silver Gray
	84 Tangerine		2283 Red		2930 Blue		246 Teal		71 Shadow Gray
	2119 Orange		49 Burgundy		67 Bright Blue		307 Dark Aqua		20 White
	44 Orange		78 Vivid Rose		2051 Blue		106 Brilliant Green		05 Ivory
	2662 Red		133 Raspberry		97 Bristol Blue		2586 Green		121 Silver Metallic
	415 Fire Red		128 Plum		157 Sultan Bue		146 Lt. Kelly Green		131 Gold Metallic
	143 Poppy Red		2856 Purple		2870 Blue		156 Vivid Green		

*Actual colors may vary slightly from examples shown due to limitations in the printing process.

TRANSLUCENT VINYL

ORACAL 8300 3mil • 5 Year • Transparent Colored Vinyl Film













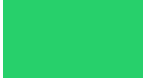











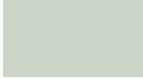
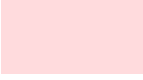

8300 is perfect for creating stunning stained glass effects and color overlays. ORACAL Series 8300 offers impressive cutting and weeding properties as well as minimal shrinkage for permanent, durable, internally illuminated signs and window graphics. ORACAL 8300 is thermal print compatible and suitable for both wet and dry application. Available in 30 vibrant colors.

Recommended Application:

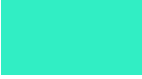
- Glass • Glasslike Surface • Indoors and Outdoors • Windows

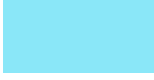

Colors and Sizes vary (*Please Call for Availability*)

	025 Brimstone Yellow		032 Light Red		053 Light Blue		061 Green
	021 Yellow		031 Red		052 Azure Blue		097 Blue Green
	020 Golden Yellow		030 Dark Red		051 Gentian Blue		060 Dark Green
	034 Orange		041 Pink		057 Traffic Blue		074 Middle Gray
	035 Pale Pink		077 Telemagenta		049 King Blue		073 Dark Gray
	089 Salmon		040 Violet		056 Turquoise		079 Reddish Brown
	047 Orange Red		056 Ice Blue		063 Lime-tree Green		
	033 Red Orange		096 Steel Blue		066 Grass Green		

*Actual colors may vary slightly from examples shown due to limitations in the printing process.

ORACAL 8500 Series 3 mil • 7 Year • High Performance PVC Vinyl Film

8500 Series meets the demands of internally illuminated signage with a 7-year durability and unbeatable color consistency from roll-to-roll. The silk-matte finish is perfect for reducing undesired reflection and the workability will change the way you think about translucent film. Series 8500 Film has been designed for producing highquality illuminated signs on rigid and thermoformed surfaces, and has been approved for prethermoforming.

Recommended Application:

- Interior/Exterior Graphics • Glass • Backlit Signs



Colors and Sizes vary (*Please Call for Availability*)

010 White	025 Yellow Brimstone	021 Yellow	013 Zinc Yellow	020 Golden Yellow	207 Ochre Yellow	542 Caribic Blue	065 Cobalt Blue	007 Dark Blue	541 Dark Turquoise	066 Turquoise Blue	054 Turquoise
034 Orange	330 Fox Red	323 Red Coral	032 Light Red	329 Carnation Red	016 Crimson	062 Light Green	063 Lime-Tree Green	009 Middle Green	614 Reed Green	068 Grass Green	618 Dragon Green
031 Red	017 Cherry Red	030 Dark Red	085 Pale Pink	413 Light Pink	041 Pink	087 Emerald	060 Dark Green	070 Black	074 Middle Gray	076 Telegray	072 Light Gray
008 Heather Red	040 Violet	403 Light Violet	012 Lilac	527 Pastel Blue	053 Light Blue	805 Ivory	011 Pale Brown	081 Light Brown	088 Coffee Brown	090 Silver Gray	031 Gold
052 Azure Blue	051 Gentian Blue	528 Gray Blue	005 Middle Blue	006 Intensive Blue	049 King Blue						

*Actual colors may vary slightly from examples shown due to limitations in the printing process.

TRANSLUCENT VINYL

ORACAL 8510 3mil • 7 Year • Translucent Etched Glass

8510 gives an amazing etched look without having to use a sandblaster or etching cream. Ideal for decorative design of shop window or glass door. Wet application is recommended. Create beautiful window graphics Indoor or outdoors!

Recommended Application:

- Shop Windows • Glass Doors



Sizes vary (Please Call for Availability)

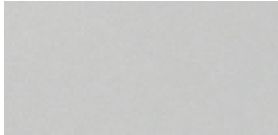

Fine Silver

*Actual colors may vary slightly from examples shown due to limitations in the printing process.



ARLON

DPF 6500 2 mil • 7 Year • Premium Translucent Cast Film

Repositionable ✓ Air Release ✓ Eco-Solvent ✓ Solvent ✓ Latex ✓ UV ✓

Clear Solvent Adhesive

DPF 6500 is a gloss white, cast, translucent film with a permanent pressure-sensitive adhesive. Designed for backlit graphics, DPF 6500 is made of a premium cast facestock with a special lay-flat liner. The film provides superior print resolution and image quality.

Recommended Applications:

- Windows
- Second Surface Signs

SKU	SIZE
4065-3015-020	30"X50YD
4065-5406-020	54"X20YD





PREMADE PRODUCTS

SCROLL BRACKETS

PREMIUM SERIES SCROLL BRACKETS

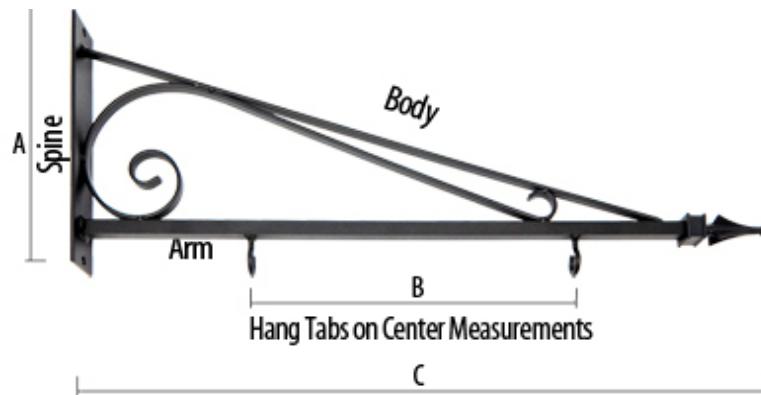

SPECIFICATIONS

Description	SKU	A	B	C	Spine	Body	Arm	Hang Tabs
20" Premium Scroll Bracket	SB20-Prem	8"	8"	20"	3/16" x 1 1/2" w/ 3/8" Holes	3/16" x 1/2"	1/2" x 1/2"	3/16" Wire w/ 1/2" Hole
26" Premium Scroll Bracket	SB26-Prem	9"	12"	26"	3/16" x 2" w/ 3/8" Holes	3/16" x 1/2"	5/8" x 5/8"	1/4" Wire w/ 5/8" Hole
30" Premium Scroll Bracket	SB30-Prem	10 1/2"	14"	30"	3/16" x 2" w/ 3/8" Holes	3/16" x 1/2"	5/8" x 5/8"	1/4" Wire w/ 5/8" Hole
36" Premium Scroll Bracket	SB36-Prem	10 1/2"	20"	36"	3/16" x 2" w/ 3/8" Holes	3/16" x 1/2"	5/8" x 5/8"	1/4" Wire w/ 5/8" Hole
42" Premium Scroll Bracket	SB42-Prem	11 3/4"	21 7/8"	42"	3/16" x 2" w/ 3/8" Holes	3/16" x 1/2"	5/8" x 5/8"	1/4" Wire w/ 5/8" Hole

STANDARD SERIES SCROLL BRACKETS

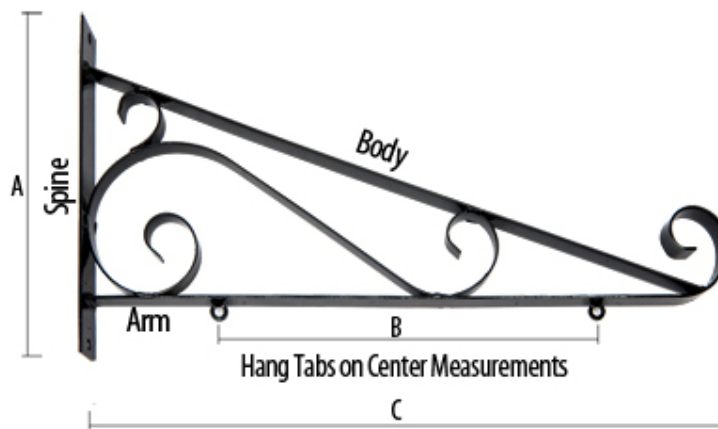

SPECIFICATIONS

Description	SKU	A	B	C	Spine	Body	Arm	Hang Tabs
18" Standard Scroll Bracket	SB18	11"	6 1/4"	18"	1/16" x 1 1/4" w 1/4" Holes	1/16" x 3/4"	1/16" x 3/4"	3/8" Washers
24" Standard Scroll Bracket	SB24	11"	10 1/4"	24"	1/8" x 1 1/4" w/ 1/4" Holes	1/8" x 1"	1/8" x 1"	3/8" Washers
30" Standard Scroll Bracket	SB30	15"	17 1/4"	30"	1/8" x 1 1/2" w/ 1/4" Holes	1/8" x 1"	1/8" x 1"	3/8" Washers
36" Standard Scroll Bracket	SB36	15"	20 7/8"	36"	1/16" x 1 1/2" w/ 1/4" Holes	1/16" x 1"	1/16" x 1"	3/8" Washers
42" Standard Scroll Bracket	SB42	16"	24"	42"	1/8" x 1 1/2" w/ 1/4" Holes	1/8" x 1"	1/8" x 1"	3/8" Washers
48" Standard Scroll Bracket	SB48	16"	23"	48"	1/8" x 1 1/2" w/ 1/4" Holes	1/8" x 1"	1/8" x 1"	3/8" Washers

*Custom made for NEPCO, therefore pricing will be higher on 30" than 48".

NEW ENGLAND SERIES SCROLL BRACKET

Chatham

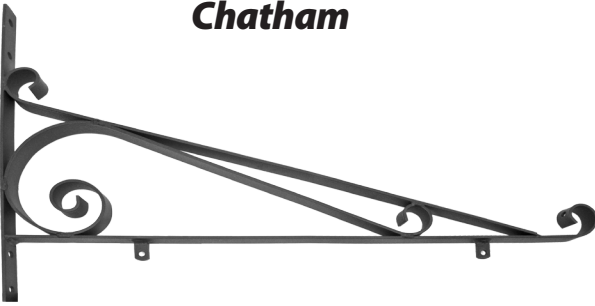

Essex

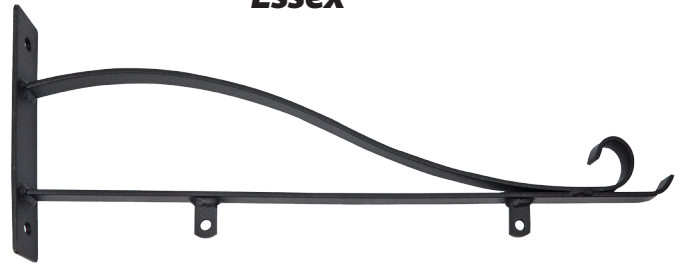

Mystic



Nantucket



Newport

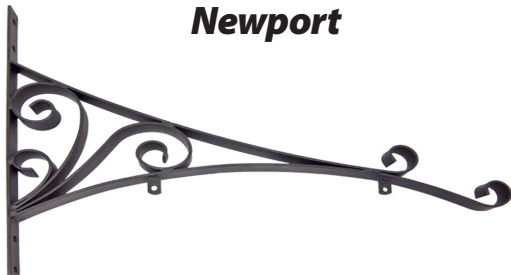

Slater



Mt. Hope



New Bedford

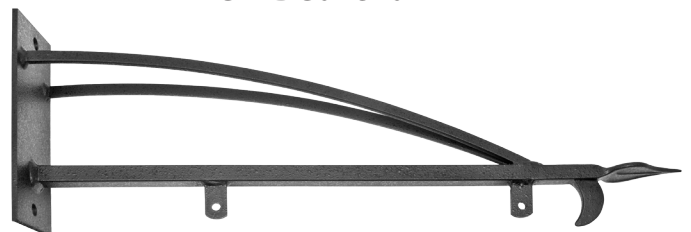

Wickford



SEE SPECIFICATIONS ON NEXT PAGE

SCROLL BRACKETS

Special Notes:

- Chatham and Newport spine has four holes for additional support.
- All Brackets have a black textured powder coated finish.
- Custom Steel Bracket work available - scaled drawing required for estimating.

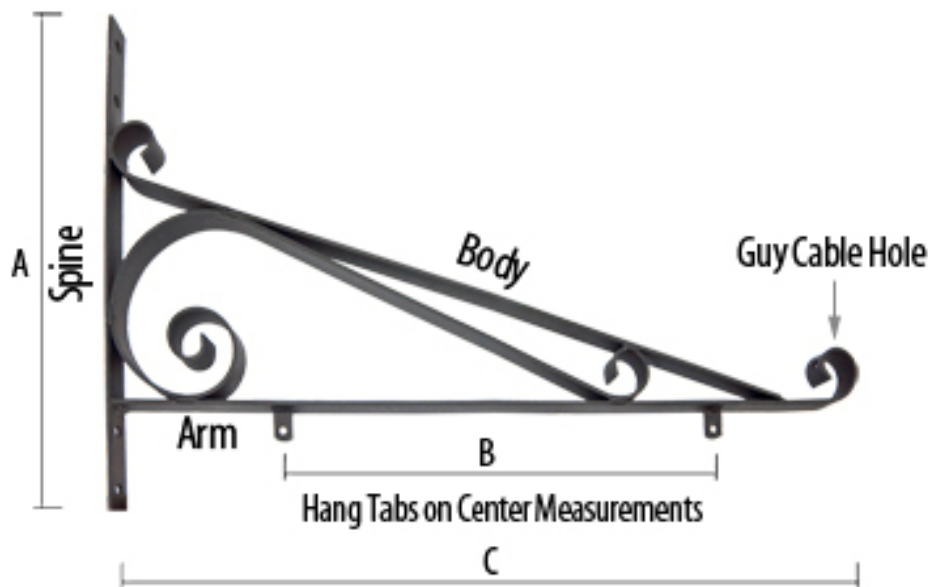

SPECIFICATIONS

Description	SKU #	A	B	C	Spine	Body	Arm	Hang Tabs
30" Essex	SB30-100	11"	14"	30"	1/4" x 2" w/ 9/16" holes	1/4" x 1"	1/4" x 1"	1/4" x 1" w/ 7/16" holes
42" Essex*	SB42-101	13 1/2"	24"	42"	1/4" x 2" w/ 9/16" holes	1/4" x 1 1/2"	1/4" x 1 1/2"	1/4" x 1" w/ 7/16" holes
30" Nantucket	SB30-102	11 1/2"	14"	30"	1/4" x 2" w/ 9/16" holes	1/4" x 1"	1/4" x 1"	1/4" x 1" w/ 7/16" holes
42" Nantucket*	SB42-103	14 1/2"	24"	42"	1/4" x 2" w/ 9/16" holes	1/4" x 1 1/2"	1/4" x 1 1/2"	1/4" x 1" w/ 7/16" holes
30" Wickford	SB30-104	11 1/4"	14"	30"	1/4" x 2" w/ 9/16" holes	1/4" x 1"	1/4" x 1"	1/4" x 1" w/ 7/16" holes
42" Wickford*	SB42-105	13 1/2"	24"	42"	1/4" x 2" w/ 9/16" holes	1/4" x 1 1/2"	1/4" x 1 1/2"	1/4" x 1" w/ 7/16" holes
42" New Bedford	SB42-107	11"	24"	42"	1/4" x 4" w/ 9/16" holes	3/4" x 3/4"	1/4" x 1/2"	1/4" x 1" w/ 7/16" holes
30" Mount Hope	SB30-108	10 1/2"	14"	30"	1/4" x 4" w/ 9/16" holes	3/4" x 3/4"	1/4" x 1/2"	1/4" x 1" w/ 7/16" holes
42" Mount Hope	SB42-109	11"	24"	42"	1/4" x 4" w/ 9/16" holes	3/4" x 3/4"	1/4" x 1/2"	1/4" x 1" w/ 7/16" holes
36" Newport*	SB36-110	28"	16 1/2"	36"	1/4" x 1 1/2" w/ 9/16" holes	1/4" x 1 1/2"	1/4" x 1 1/2"	1/4" x 1" w/ 7/16" holes
48" Newport*	SB48-111	32 1/2"	22 1/4"	48"	1/4" x 1 1/2" w/ 9/16" holes	1/4" x 1 1/2"	1/4" x 1 1/2"	1/4" x 1" w/ 3/8" holes
60" Newport*	SB60-112	36 3/4"	27 1/2"	60"	1/4" x 1 1/2" w/ 9/16" holes	1/4" x 1 1/2"	1/4" x 1 1/2"	1/4" x 1" w/ 3/8" holes
42" Chatham*	SB42-113	26"	24"	42"	1/4" x 1 1/2" w/ 9/16" holes	1/4" x 1 1/2"	1/4" x 1 1/2"	1/4" x 1" w/ 3/8" holes
54" Chatham*	SB54-114	25 1/2"	34"	54"	1/4" x 1 1/2" w/ 9/16" holes	1/4" x 1 1/2"	1/4" x 1 1/2"	1/4" x 1" w/ 3/8" holes
30" Slater	SB30-115	12"	14"	30"	1/4" x 2" w/ 9/16" holes	1/4" x 1"	1/4" x 1"	1/4" x 1" w/ 3/8" holes
42" Slater*	SB42-116	13 1/2"	24"	42"	1/4" x 2" w/ 9/16" holes	1/4" x 1 1/2"	1/4" x 1 1/2"	1/4" x 1" w/ 3/8" holes
30" Mystic	SB30-117	11 1/4"	14"	30"	1/4" x 2" w/ 9/16" holes	1/4" x 1"	1/4" x 1"	1/4" x 1" w/ 3/8" holes
42" Mystic*	SB42-118	13 1/2"	24"	42"	1/4" x 2" w/ 9/16" holes	1/4" x 1 1/2"	1/4" x 1 1/2"	1/4" x 1" w/ 3/8" holes

*Guy Cable Hole = 1/2"

WALL MOUNT Straight Arm Brackets

- **FOUR UNIQUE STYLE FINIALS**
- **EXTRA WIDE SPINE (BASE PLATE)**
- **FOR MORE SURFACE ATTACHMENT TO WALL**

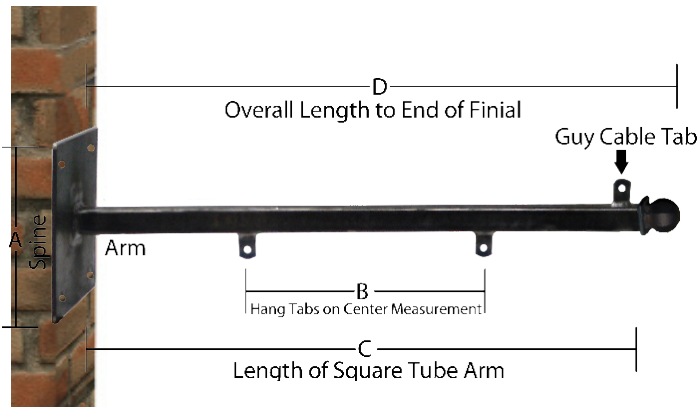

Special Notes:

- All steel brackets are powder coated textured black paint.
- Custom Steel Bracket work available - scaled drawing required for estimating.
- **Guy Cable Hole = 1/4" X 1" w/ 7/16" Hole**

SPECIFICATIONS

SKU	A	B	C	D	Spine	Arm	Hang Tabs
SB36-119	10"	20"	36"	36 1/2"	1/4" X 10" X 10" w/ 9/16" Holes	1 1/2" X 1 1/2" X 1/8" Wall	1/4" X 1" w/ 7/16" Holes
SB48-120	10"	28"	48"	48 1/2"	1/4" X 10" X 10" w/ 9/16" Holes	1 1/2" X 1 1/2" X 1/8" Wall	1/4" X 1" w/ 7/16" Holes
SB60-121	10"	40"	60"	60 1/2"	1/4" X 10" X 10" w/ 9/16" Holes	1 1/2" X 1 1/2" X 1/8" Wall	1/4" X 1" w/ 7/16" Holes
SB36-122	10"	20"	36"	38 1/2"	1/4" X 10" X 10" w/ 9/16" Holes	1 1/2" X 1 1/2" X 1/8" Wall	1/4" X 1" w/ 7/16" Holes
SB48-123	10"	28"	48"	50 1/2"	1/4" X 10" X 10" w/ 9/16" Holes	1 1/2" X 1 1/2" X 1/8" Wall	1/4" X 1" w/ 7/16" Holes
SB60-124	10"	40"	60"	62 1/2"	1/4" X 10" X 10" w/ 9/16" Holes	1 1/2" X 1 1/2" X 1/8" Wall	1/4" X 1" w/ 7/16" Holes
SB36-125	10"	20"	36"	44 1/2"	1/4" X 10" X 10" w/ 9/16" Holes	1 1/2" X 1 1/2" X 1/8" Wall	1/4" X 1" w/ 7/16" Holes
SB48-126	10"	28"	48"	56 1/2"	1/4" X 10" X 10" w/ 9/16" Holes	1 1/2" X 1 1/2" X 1/8" Wall	1/4" X 1" w/ 7/16" Holes
SB60-127	10"	40"	60"	68 1/2"	1/4" X 10" X 10" w/ 9/16" Holes	1 1/2" X 1 1/2" X 1/8" Wall	1/4" X 1" w/ 7/16" Holes
SB36-128	10"	20"	36"	42 1/4"	1/4" X 10" X 10" w/ 9/16" Holes	1 1/2" X 1 1/2" X 1/8" Wall	1/4" X 1" w/ 7/16" Holes
SB48-129	10"	28"	48"	54 1/4"	1/4" X 10" X 10" w/ 9/16" Holes	1 1/2" X 1 1/2" X 1/8" Wall	1/4" X 1" w/ 7/16" Holes
SB60-130	10"	40"	60"	66 1/4"	1/4" X 10" X 10" w/ 9/16" Holes	1 1/2" X 1 1/2" X 1/8" Wall	1/4" X 1" w/ 7/16" Holes
*SB48-131-ADJ	10"	adjustable	48"	48 1/2"	1/4" X 10" X 10" w/ 9/16" Holes	1 1/2" X 1 1/2" X 1/8" Wall	5/16" S.S. Eyebolts w/HDWE
*SB60-132-ADJ	10"	adjustable	60"	60 1/2"	1/4" X 10" X 10" w/ 9/16" Holes	1 1/2" X 1 1/2" X 1/8" Wall	5/16" S.S. Eyebolts w/HDWE
*SB48-133-ADJ	10"	adjustable	48"	50 1/2"	1/4" X 10" X 10" w/ 9/16" Holes	1 1/2" X 1 1/2" X 1/8" Wall	5/16" S.S. Eyebolts w/HDWE
*SB60-134-ADJ	10"	adjustable	60"	62 1/2"	1/4" X 10" X 10" w/ 9/16" Holes	1 1/2" X 1 1/2" X 1/8" Wall	5/16" S.S. Eyebolts w/HDWE
*SB48-135-ADJ	10"	adjustable	48"	56 1/2"	1/4" X 10" X 10" w/ 9/16" Holes	1 1/2" X 1 1/2" X 1/8" Wall	5/16" S.S. Eyebolts w/HDWE
*SB60-136-ADJ	10"	adjustable	60"	68 1/2"	1/4" X 10" X 10" w/ 9/16" Holes	1 1/2" X 1 1/2" X 1/8" Wall	5/16" S.S. Eyebolts w/HDWE
*SB48-137-ADJ	10"	adjustable	48"	54 1/2"	1/4" X 10" X 10" w/ 9/16" Holes	1 1/2" X 1 1/2" X 1/8" Wall	5/16" S.S. Eyebolts w/HDWE
*SB60-138-ADJ	10"	adjustable	60"	66 1/4"	1/4" X 10" X 10" w/ 9/16" Holes	1 1/2" X 1 1/2" X 1/8" Wall	5/16" S.S. Eyebolts w/HDWE

POLE MOUNT Straight Arm Brackets

- **TWO UNIQUE STYLE FINIALS**
 - **NARROW SPINE (BASE PLATE)**
 - **TO ATTACH TO A VARIETY OF NARROW POST**

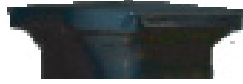

NARROW SPINE (BASEPLATE) SPECIFICALLY DESIGNED FOR POLE MOUNT APPLICATIONS.

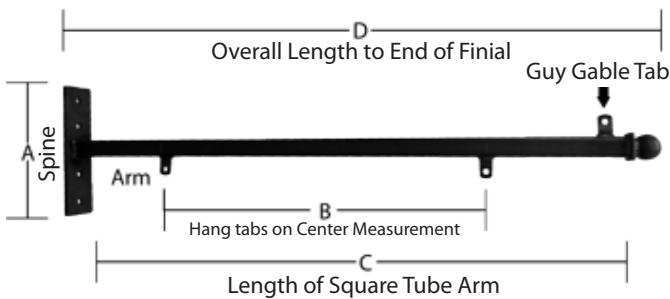

Special Notes:

- All steel brackets are powder coated textured black paint.
- Custom Steel Bracket work available - scaled drawing required for estimating.
- * Pole mount straight arm brackets can be mounted to walls

Pole Mount Baseplate Size

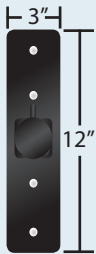

Fixed, Welded Hang Tabs Only

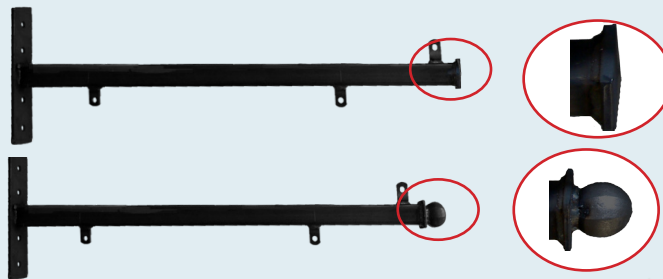

SPECIFICATIONS

SKU	A	B	C	D	Spine	Arm	Hang Tabs	Guy Cable Tab	End Style
SB36-139	12"	20"	36"	36½"	⅜" X 12" X 3" w/ ⅙" Holes	1½" X 1½" X ⅛" Wall	¼" X 1" w/ ⅙" Holes	¼" X 1" w/ ⅙" Hole	Flat End
SB48-140	12"	28"	48"	48½"	⅜" X 12" X 3" w/ ⅙" Holes	1½" X 1½" X ⅛" Wall	¼" X 1" w/ ⅙" Holes	¼" X 1" w/ ⅙" Hole	Flat End
SB60-141	12"	40"	60"	60½"	⅜" X 12" X 3" w/ ⅙" Holes	1½" X 1½" X ⅛" Wall	¼" X 1" w/ ⅙" Holes	¼" X 1" w/ ⅙" Hole	Flat End
SB36-142	12"	20"	36"	38½"	⅜" X 12" X 3" w/ ⅙" Holes	1½" X 1½" X ⅛" Wall	¼" X 1" w/ ⅙" Holes	¼" X 1" w/ ⅙" Hole	Ball End
SB48-143	12"	28"	48"	50½"	⅜" X 12" X 3" w/ ⅙" Holes	1½" X 1½" X ⅛" Wall	¼" X 1" w/ ⅙" Holes	¼" X 1" w/ ⅙" Hole	Ball End
SB60-144	12"	40"	60"	62½"	⅜" X 12" X 3" w/ ⅙" Holes	1½" X 1½" X ⅛" Wall	¼" X 1" w/ ⅙" Holes	¼" X 1" w/ ⅙" Hole	Ball End

PROJECTION STATIONARY BRACKETS



Projection stationary brackets are welded & prepunched using the highest grade of 1/4" wall plate. Horizontal projection tubes are made of 1" x 1" x 1/8" heavy square steel with end caps for protection from moisture penetration. Each bracket is textured powder coated black for ultimate weather protection.



SKU

SB26-139

SB34-140

SB46-141

A

13"

B

26"

C

3"

D

1/4" X 8"

E

7/16"

3 Size Options!

MOUNTING EXAMPLES

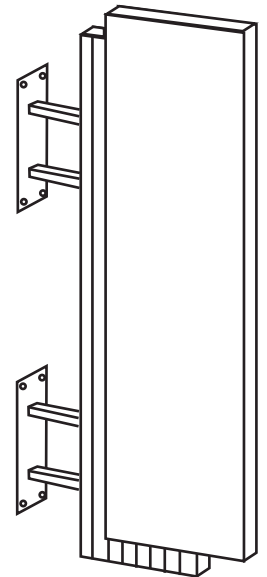
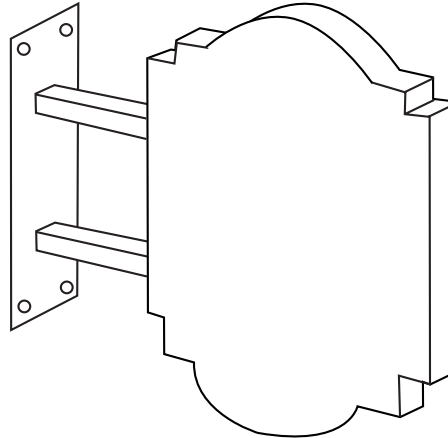
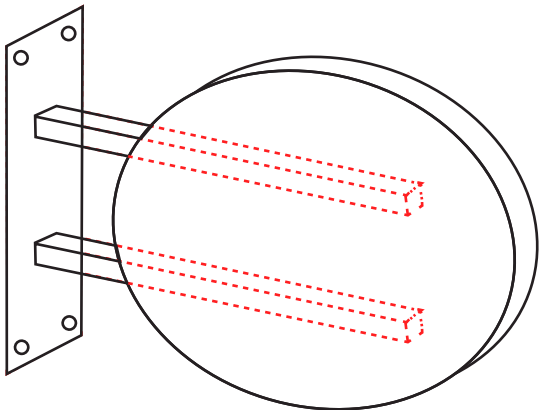

All Projection Stationary Brackets can be used with Single Face & Double Faced Applications!

UNIVERSAL SIGN BRACKETS

Designed to be used with a wide variety of signage types including, but not limited to, **high density urethane, wood, illuminated & non-illuminated** types of signage.

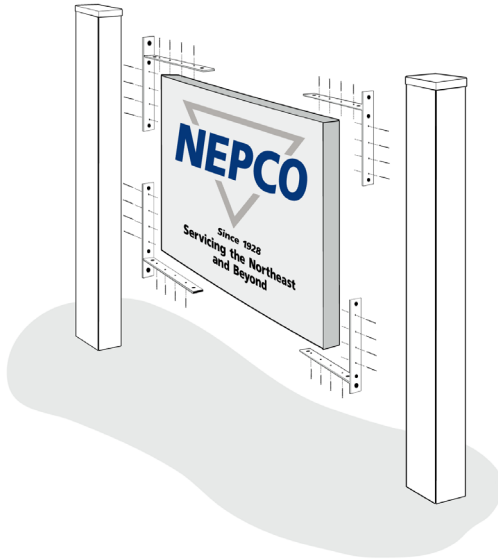

Universal Sign Brackets are welded & prepunched using the highest grade of $\frac{3}{16}$ " steel available. Each bracket is powder coated white for ultimate protection and has four $\frac{21}{64}$ " holes in each corner & $\frac{1}{4}$ " counter sink for multifastening options.

SKU	VERTICAL DIMENSION	HORIZONTAL DIMENSION
UNIV-XSM	7.5"	6- $\frac{3}{16}$ "
UNIV-SM	13.5"	11.5"
UNIV-MED	24"	22"
UNIV-LG	24"	44"

4 Bracket Options!

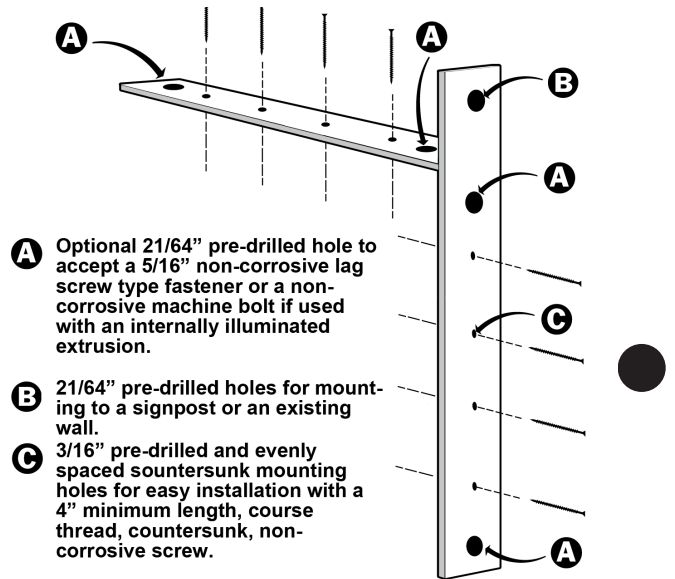

- A** Optional $\frac{21}{64}$ " pre-drilled hole to accept a $\frac{5}{16}$ " non-corrosive lag screw type fastener or a non-corrosive machine bolt if used with an internally illuminated extrusion.
- B** $\frac{21}{64}$ " pre-drilled holes for mounting to a signpost or an existing wall.
- C** $\frac{3}{16}$ " pre-drilled and evenly spaced countersunk mounting holes for easy installation with a 4" minimum length, coarse thread, countersunk, non-corrosive screw.

SIGN MOUNTING EXAMPLES

BETWEEN POLE MOUNT

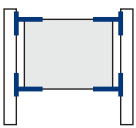

BOTTOM/TOP MOUNT EXISTING

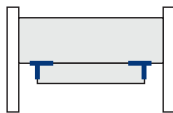

MULTI BETWEEN POLE

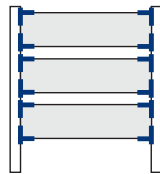

WALL MOUNT PROJECTION

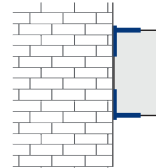

BETWEEN POLE MIX & MATCH

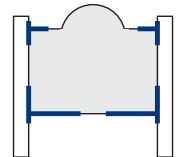

UNDER CANOPY MOUNT

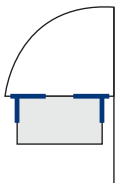

DOUBLE PROJECTION

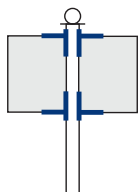

SIDE MOUNT EXISTING

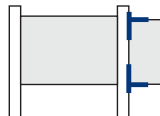

SINGLE BRACKET PROJECTION

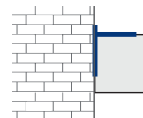

SINGLE POLE PROJECTION

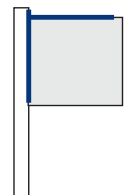

The Multi-Use Sign Hanger

Fits Perfectly on any post 3"x3" or Greater. Attaches to Wood, Metal, or Nearly Any Substrate Using Stainless Steel Screws.

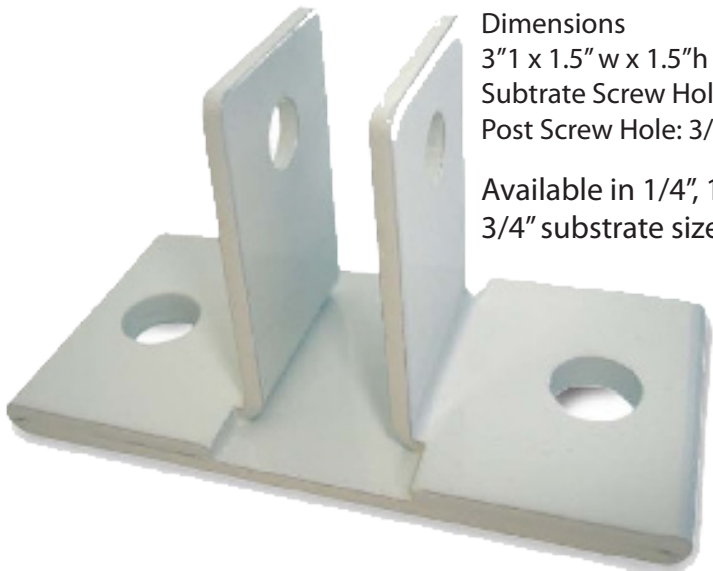

Dimensions
 3"1 x 1.5" w x 1.5"h
 Substrate Screw Hole: 1/4"
 Post Screw Hole: 3/8"

Available in 1/4", 1/2", &
 3/4" substrate sizes

Post Clip™ Features

- Strong and Lightweight
- .090 Corrosion-Resistant **Stainless Steel**
- Strong, Folded, Single-Piece Construction
- Bright White, Powder-Coated Finish

Post Clip™ Benefits

- SAVES TIME AND MONEY WITH EASY INSTALLATION
- Eliminates Sign Failure From Sagging or Twisted L-Bracket
- No Welds to Break
- **NO RUST!**



Order by Substrate Thickness
 (1/4", 1/2" or 3/4").

Available Individually or
 in Case Quantity (100 pcs/case)
 (Parts are individual plastic bagged to
 prevent scratching)

SKU	SIZE
1/4PSTCLP-SS	1/4"
1/2PSTCLP-SS	1/2"
3/4PSTCLP-SS	3/4"

*Be Sure That It's a Stainless Steel Post Clip™
 Will Not Bend, Tear or Break.*

PLASTICADE®

The Billboard™

- Twice as big as a Signicade
 - perfect for eye-catching outdoor advertising
- Six Signs per Frame
 - two 36" x 48" signs
 - two side signs
 - two sided top rider
- Wheels for easy movement
 - no installation needed
- Quick-Change™ Feature
 - change signs in seconds, slide in a sign
- "Stay Tabs" hold main signs securely in place
- Internally weight with dry sand

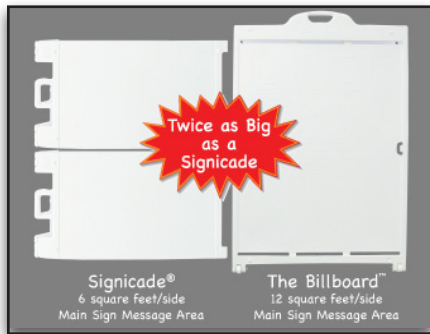

Outside Dimensions: 58"H x 39"W x 3.125"D
 Dimensions of Recessed Area: 46.75"H 36.25"W
 Weight 45 lbs.



MESSAGING

SKU	SIZE
A-FRAME-198W	58"H x 39"W x 3.125"D

PLASTICADE®

Signicade® Deluxe

- Change signs in seconds
 - With patented Quick-Change™ feature, signs easily slide in and out
 - Use Coroplast™ signs or other rigid sign material 3/16" thick or less
 - Holds two signs, 24"W x 36"H
- Stay Tabs™ ensure signs stay securely in place
- No Maintenance
 - All plastic, use indoors and out
- No tape, Velcro®, or screws needed
 - Eliminates fastener damage to signs
- Can internally weight with sand
- Hinges lock in open position



Outside Dimensions: 46.375"H x 27.125"W x 3.125"D
 Weight: 20 lbs



SKU	SIZE
A-FRAME-DLX-BLK	46.375"H x 27.125"W x 3.125"D
A-FRAME-DLX-WHT	46.375"H x 27.125"W x 3.125"D

PLASTICADE®

Signicade®

- All Plastic Sign Frame
- Recessed sign area helps to protect sign faces
- Holds two signs, 24"W x 36"H
- Sign face can receive vinyl sheeting (with surface preparation), metal, Coroplast™, or acrylic sign blanks
- Can be internally ballasted with sand
- Molded-in handle for easy portability
- Stacking lugs facilitate handling by keeping stacked units from sliding and damaging sign faces



Outside Dimensions:
45"H X 25"W x 3"D
Dimensions of Recessed
Panel: 36.0625"H x 24"W
Weight: 18 lbs

SKU

SIZE

A-FRAME-PLAS

45"H X 25"W x 3"D

PLASTICADE®

Quik Sign®

- Change signs in seconds
- With patented Quick-Change™ feature, signs easily slide in and out
- Use Coroplast signs or other rigid material
- 3/16" thick or less
- Holds two signs, 24"W x 18"H
- "Grabber Hinges" hold a sign rider
- All plastic sign frame - no rust, splinters, discoloration, or maintenance
- Won't tear or scratch car seat upholstery
- Molded-in handle assures easy portability
- Stacking lugs nest into each other when units are stacked which prevents sliding



Outside Dimensions:
31.5"H x 26"W x 2"D
Weight: 7.5 lbs

SKU

SIZE

QUIK

31.5"H x 26"W x 2"D

Real Estate Frame

- High Quality.
- Heavy Duty Construction.
- CLIP-IN or BOLT IN. (Clips are not included)
- Made in the U.S.A.
- Available with a BLACK or WHITE powder coat finish*!

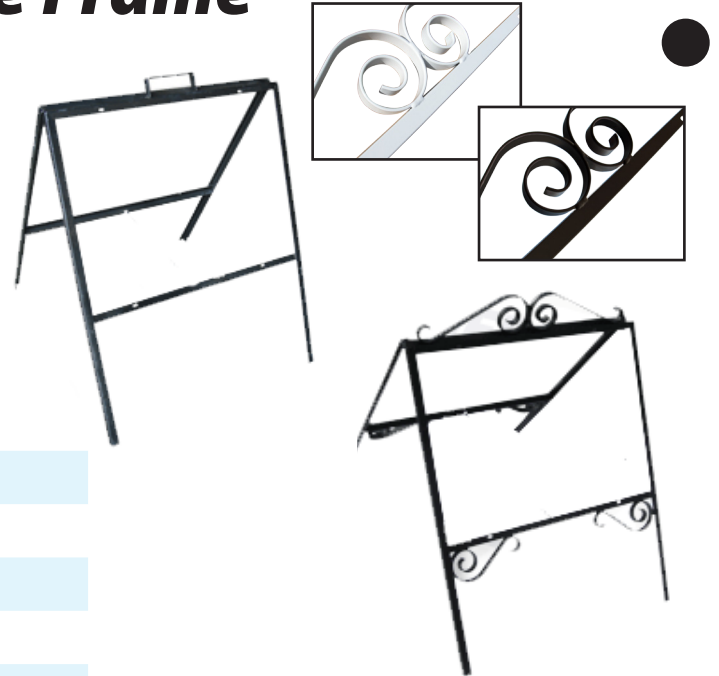

SKU	SIZE
C-FF24	18"H x 24"W
D-FF36	36" H x 24"W
R-SCROLL-BLK	18"H x 24"W
R-SCROLL-WHT	18"H x 24"W
W-SCROLL-WHT	24"H x 36"W

Windsigns Frame

Bundle Packs

- Resists head-on winds up to 60 mph (wind resistance varies for each size frame)
- Change signs in seconds
- “Quick-Change”™ feature, signs easily slide in and out
- Use Coroplast™ signs or other material 3/16” thick or less
- All plastic frame (Eliminates torn, bent, or rusted frames) powder coat finish*!
- Plastic base has two built-in wheel (Can be filled with dry sand)
- Tool free assembly



Specifications:

Color: Grey
 Dimensions (Frame Only): 42.9"H x 26"W x 2.5"D
 Dimensions (Base Only): 7.1"H x 28.7"W x 18.1" D
 Dimensions Assembled: 53"H x 28.7"W
 Total Weight Assembled: 25 lbs.
 Weight (Base Only): 9 lbs.
 Base Sand Ballasting: Use a max. of 115 lbs. of dry sand
 Sign Insert Size: 24" x 36" (3/16" thick)
 Sign Insert Weight Limit: Max. of 5 lbs. per side

SKU	SIZE
1822-SIGN-KIT	2' x 3' Sign-Kit
1822-BASE-KIT	2' x 3' Base-Kit
1833-SIGN-KIT*	28" x 44" Sign-Kit
1833-BASE-KIT*	28" x 44" Base-Kit

*Deluxe Grey

In this deal you will be receiving one of each:
 1822-SIGN-KIT - 1822 Windsign II 2' x 3' Sign-Kit
 1822-BASE-KIT - 1822 Windsign II 2' x 3' Base-Kit

In this deal you will be receiving one of each:
 1833-SIGN-KIT - 1833 Windsign Deluxe 28" x 44" Sign-Kit
 1833-BASE-KIT - 1833 Windsign Deluxe 28" x 44" Base-Kit

STABLE FOR HIGH-WINDS, HEAVY TRAFFIC AREAS, SCHOOLS, MALLS, ECONOMICAL AND PEDESTRIAN FRIENDLY!

Our rubber and steel sign bases are ideal for parking lots, crosswalks, guard booths, schools, malls, industrial and construction sites, or anywhere portable or where temporary signs are needed.

Our 60lb. rubber base unit is stable enough to withstand high winds and bad weather, as well as heavy traffic areas. For excessive high wind areas there is also an optional 30 pound extender to add to our octagon bases creating additional stability. (Special Order Only.) Our 30lb. rubber base & our 22lb. steel bases are ideal for indoor or light temporary use.

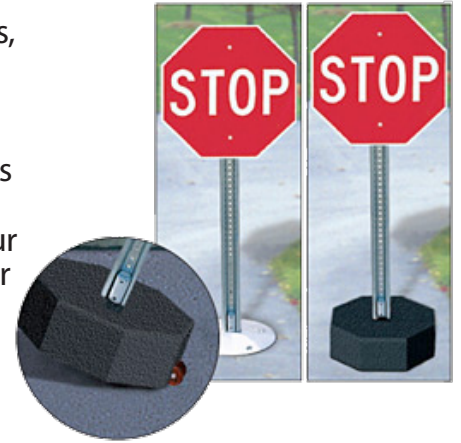

22lb. Steel Base -
w/Set Screw Bolt



30lb. Rubber Base

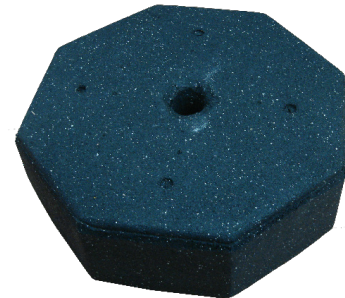

60lb. Rubber Base

SKU	WEIGHT
GP4-BASE	22 LB.
TSB-30-BASE	30 LB.
TSB-60-BASE	60 LB.

DON'T FORGET ABOUT YOUR ADDITIONAL ACCESSORIES!

Base Wheels
SKU: TSB-WHEELS



12" Adapter -
w/2 Bolts
SKU: TSB-ADP



6' U-Channel
Post
SKU: U-6-1LB



9lb. Steel Post
SKU: GP-POST



60" PVC Post -
w/2 Brackets
SKU: TSB-POST-5



Aluminum Sign Post

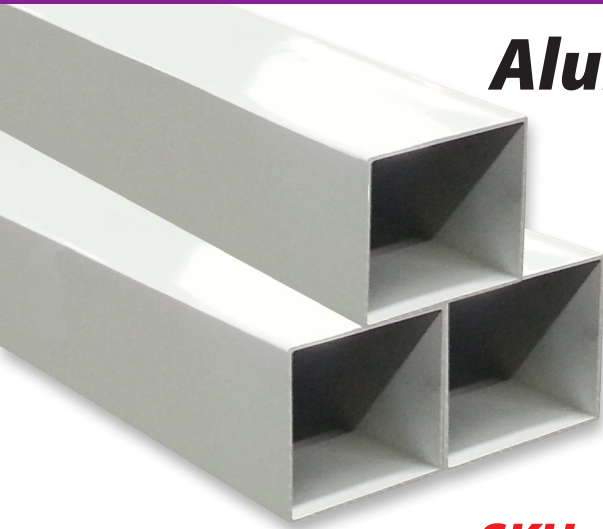

- Will not Crack, Rot, Twist or Warp!
- No Painting Required!
- No Trips to the Lumber Yard Needed!
- Comes with a Plastic Protective Sleeving
- Bright White, Powder-Coated Finish

SKU	SIZE
A-1480-123	2" x 2" x 8' x .093"
A-1480-124	2" x 2" x 12' x .093"
WLB-582-10	4" x 4" x 10' x .125"
WLB-605-1	6" x 6" x 16' x .150"
WLB-605-8	6" x 6" x 8' x .150"

Galvanized Steel Square Sign Post

Known for superior strength and a geometry that allows signage to be mounted in 4 different directions, square posts have become a common choice for many municipalities.



SKU	BASE
SPSQ10	10'
SPSQ12	12'
SPSQ3	3'

Galvanized Steel Round Sign Post

Providing an esthetic appearance and durable exterior life, cities, counties and state departments use round posts as their choice of sign post.

SKU	BASE
SPR10	10'
SPR12	12'



U-Channel Sign Post



U-channel posts are the most common post used throughout the United States. They are also one of the most economical choices for a sign mounting post. U-channel posts are available in both green and galvanized.

SKU	BASE
U-16-1LB*	6'
U-6*	6'
U-8-1LB*	8'
U-8*	8'
U-8-GALV**	8'
U-10*	10'
U-10-GALV**	10'
U-12*	12'
U-12-GALV**	12'

* Color = Green

**Galvanized

Plastic Caps

All stocking post caps are designed to be used with with aluminum square posts. They can be used with wooden posts but adjustments will need to be made.



Dome



Ball



Teardrop



Gothic



Coachman



Newport



Bridgeport



Federation



Princeton



**Classic
New England**



Nantucket



Hampton



Cambridge



Classic



Horse



Over Pyramid



Flat



**Internal
Pyramid**



**Internal
Flat Plug**



**Internal
Flat Plug**

SEE SPECIFICATIONS ON NEXT PAGE

SPECIFICATIONS

SKU	Name	Description
4CAP/DOME	Dome	4" Slide Over
4CAP/BALL	Ball	4" Slide Over
4CAP/TEARDROP	Teardrop	4" Slide Over
4CAP/GOTHIC	Gothic	4" Slide Over
4CAP/COACHMAN	Coachman	4" Slide Over
4CAP/NEWPORT	Newport	4" Slide Over
4CAP/BRIDGEPORT*	Bridgeport	4" Slide Over
4CAP/FEDERATION*	Federation	4" Slide Over
4CAP/PRINCETON*	Princeton	4" Slide Over
4CAP/CLS-NE	Classic New England	4" Slide Over
4CAP/NANTUCKET	Nantucket	4" Slip Over
4CAP/HAMPTON*	Hampton	4" Slide Over
4CAP/CAMBRIDGE	Cambridge	4" Slip Over
4CAP/CLASSIC	Classic	4" Slip Over
4CAP/HORSE*	Horse	4" Slide Over
4CAP/PYD-OVER	Over Pyramid	4" Slide Over
4CAP/FLAT	Flat	4" Slip Over
4CAP/PYD	Internal Pyramid	4" Slip In
SQR-10-14-WHT	Internal Flat Plug	2" Slip In
SQR-100MM	Internal Flat Plug	4" Slip In

** also Available in 6" Slide Over*



Aluminum Caps

All Aluminum Caps are coated with a power coated white finish.



Pyramid
2" Slide Over



Pyramid
4" Slide Over



Ball
2" Slide Over



Ball
4" Slide Over

SKU	Name	Description
18-807-D	Pyramid	2" Slide Over
18-809-D	Pyramid	4" Slide Over
18-118-ALD	Ball	2" Slide Over
18-119-ALD	Ball	4" Slide Over



RECOMMENDED TO USE WITH THE ALUMINUM POSTS

Galvanized Steel Wall Brackets

Sold in qty of 50 or by itself. Please call for pricing.



301



304



306



307

SKU	SIZE	ANGLE	HOLE	SLOT
301	3/16"x2"x2.5"x2.5"	90°	5/8"	9/16"x1"
304	3/16"x 1 1/2"x2"x2"	45°	5/8"	9/16"x1"
306	3/16"x 2"x2.5"x5"	90°	5/8"	9/16"x1"
307	3/16"x 1 1/2"x2"x2"	90°	5/8"	9/16"x1"

Boulevard Banner Brackets



Each Boulevard Banner kit comes with:

- 2/ea Aluminum Brackets
- 2 - 3/4" Diameter Round Fiberglass Rods
- 2 Split Rings
- 2 Clevis Pins
- 2 Cable Ties
- 2 Rubber Caps
- 4/ea 47" Stainless Steel Straps

Boulevard Banners decorate your city streets, school campus or mall parking lots. Banner Brackets can attach to any light or street pole! Boulevard Banners serve the multiple purposes of attracting attention while adding atmosphere and delivering important information.



SKU

SIZE

BBK18	18- 1/2" Boulevard Banner Kit
BBK24	24-1/2" Boulevard Banner Kit
BBK30	30-1/2" Boulevard Banner Kit
BBK36	36-1/2" Boulevard Banner Kit

DON'T FORGET!



Boulevard Banner Bracket Strap

SKU: BBK-STRAP



Banner Stand Retractable Economy Adjustable



Economy Single Sided Retractable Banner Stand

Viewable Graphic Size: 33.5" x 78.7"

Printed Graphic Size: 33.5" x 84.7"

The most economical retractable banner stand on the market. The Economy Retractable Banner Stand has a medium duty mechanism making it appropriate for temporary and full time displays or for advertising seasonal specials. This banner stand features a durable aluminum construction with a BLACK or SILVER finish. For easy storage, this economy banner stand and pole fold down into the base. When not in use, simply store the unit within the included bag to maintain the condition of the graphics and other components.

SKU

RU1332B-BLACK

RU1332S*

RU1333S**

RU23310S***

DIMENSIONS

39.5 x 5.5 x 5.5 in

39.5 x 5.5 x 5.5 in

39.5 x 5.5 x 5.5 in

39.5 x 5.5 x 5.5 in

*Silver Finish NON-ADJUSTABLE

**Silver Finish ADJUSTABLE HEIGHT

*** Silver or Black Finish DOUBLE FACED NON- ADJUSTABLE



Banner Stand X-Style Standard



Premium X Banner Stand

Viewable Graphic Size: 24" x 63"

Printed Graphic Size: 24" x 63"

With its professional appearance and quick setup, the Standard X Banner Stand is a lightweight display that makes a great addition to any trade show exhibit. This lightweight display is made from fiberglass and plastic.

SKU

XBS2423B

DIMENSIONS

39.5 x 11.5 x 5.5 in

CCS

Aluminum Blanks

Comes 50 per box or sold separately.

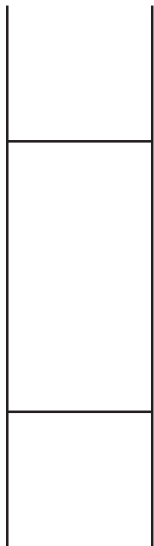

Standard Stake

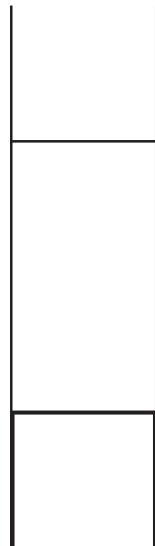

Sturdy Stake

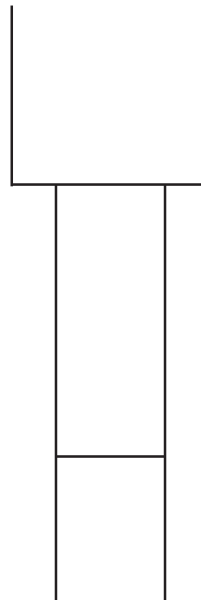

Medium Stake

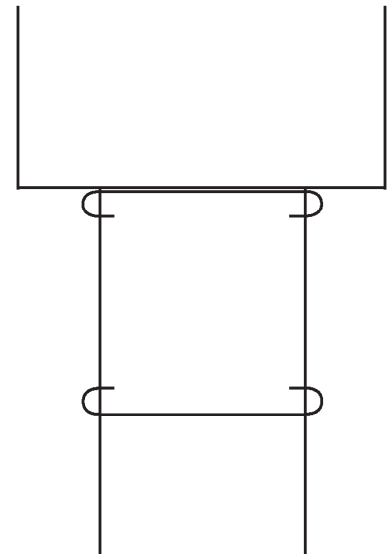

Heavy-Duty Stake

SKU	DESCRIPTION	SIZE
CORO11-RR	Standard Stake	10"W x 30"H with 7 - 1/2" Prongs
CORO1HD	Sturdy Stake	10"W x 30"H
CORO12I	Medium Stake	1/4"W x 33"H with 9" tall Prongs
CORO18I	Heavy-Duty Stake	18"W x 27"H with 9" tall Prongs

Quantity pricing available - Call for more information
 NEPCO truck delivery. UPS orders require a minimum of 100 pcs (case qty)



Don't See a Stake that Fits Your Needs? – No Problem!

If you don't see a stepstake that's listed here, we can special order one for you, provided its available to us. Keep in mind these special orders are **CASE QUANTITY** only. Call today for pricing!

Buy 100 or more Coroplast Blanks and Stakes and you will receive an amazing discount on them!

Coroplast® Brand Corrugated Plastic

Coroplast Sheeting



Features & Benefits

- No warping or bowing
- Square cut
- Consistent color
- Superior Protective Packaging
- Consistent flute size throughout
- Corona treated two sides

SKU	COLOR	SIZE
CORA-BLK	Black	4'x 8'x 4mm
CORA-BLUE	Blue	4'x 8'x 4mm
CORA-BLUE-DK	Dark Blue	4'x 8'x 4mm
CORA-BLUE-NAVY	Navy Blue	4'x 8'x 4mm
CORA-GREEN	Green	4'x 8'x 4mm
CORA-IVORY	Ivory	4'x 8'x 4mm
CORA-ORANGE	Orange	4'x 8'x 4mm
CORA-RED	Red	4'x 8'x 4mm
CORA-WHT	White	4'x 8'x 4mm
CORA-WHT-10MM	White	4'x 8'x 10mm
CORA-WHT-4X10	White	4'x 10'x 4mm
CORA-WHT-5X10	White	5'x 10'x 4mm
CORA-WHT-6MM	White	4'x 8'x 6mm
CORA-WHT-OPAQUE	White Opaque	4'x 8'x 4mm
CORA-YEL	Yellow	4'x 8'x 4mm

Coroplast Blanks

ALL BLANKS ARE TRIMMED AND SQUARED

The most economical substrate-perfect for yard signs and other temporary signage - limited exterior life. Used extensively for indoor and outdoor signage, display panels, real estate & election signs, shipping containers, packaging, and architectural modeling. Can be grommetted, mounted in sign frames, or supported with Step-Stakes. Available in a variety of colors and sizes.

SKU	COLOR	SIZE
CORA-BLK-36X24	Black	36"x 24"x 4mm
CORA-WHT-24X18	White	24"x 18"x 4mm
CORA-WHT-36X24	White	36"x 24"x 4mm
CORA-WT-OPQ2418	White Opaque	24"x 18"x 4mm
CORA-YEL-24X18	Yellow	24"x 18"x 4mm
CORA-YEL-36X24	Yellow	36"x 24"x 4mm



Sign Hangers



Galvanized Steel



Stainless Steel

* Available in small



Stainless Steel with powder coating

* Available in small

SKU	DESCRIPTION	SIZE	HOLES
6209	Galvanized Steel	3/16" thick x 1/2" wide	3/8"
LG-HANG	Stainless Steel	1/8" x 3" long x 1" wide	3/4"
LG-HANG-WHT	Stainless Steel w/ powder coating	1/8" x 3" long x 1" wide	3/4"
SM-HANG	Stainless Steel	1/8" x 3" long x 1" wide	1/2"
SM-HANG-WHT	Stainless Steel w/ powder coating	1/8" x 3" long x 1" wide	1/2"



Handicapped Parking



Size: 12 inches wide x 18 inches high
Color: White copy on Blue field
Corners: 1 1/2 inch radius
Reflectivity: Reflective
Holes: Two 3/8 inch mounting holes top and bottom centered, inset 1 1/2 inches.
Can be installed on to a post, wall, or a fence.
Meets MUTCD sign regulations for parking lots.

SKU	SIZE
HANDICAPPED-REF	12" W x 18" H



No Parking Sign



Size: 12 inches wide x 18 inches high
Color: Red copy on White field
Corners: 1 1/2 inch radius
Reflectivity: Reflective
Holes: Two 3/8 inch mounting holes top and bottom centered, inset 1 1/2 inches.
Can be installed on to a post, wall, or a fence.
Meets MUTCD sign regulations for parking lots.

SKU	SIZE
NO-PARKING	12" W x 18" H



Stop Sign



Size: 30 inches wide x 30 inches high

24 inches wide x 24 inches high

Color: White copy on Red field

Reflectivity: Reflective

Holes: Two 3/8 inch mounting holes top and bottom centered.

Can be installed on to a post, wall, or a fence.

Meets MUTCD sign regulations for parking lots.

SKU

SIZE

R1-1

30" W x 30" H

R-1-24

24" W x 24" H

STOCK NEON SIGNS

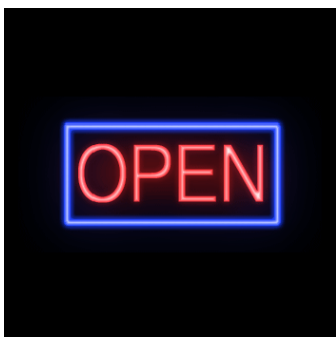

A

"Open" Neon Stock Sign. Letters Clear Red, Border Horizon Blue

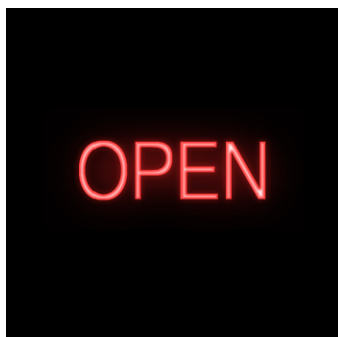

B

"Open" Neon Stock Sign. Letters Clear Red, No Border

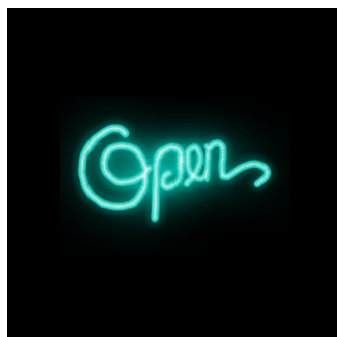

C

"Open" Neon Stock Sign. Letters Turquoise, No Border

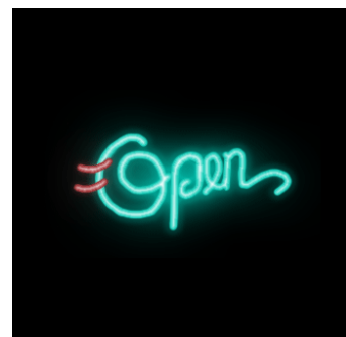

D

"Open" Neon Stock Sign. Letters Turquoise with Ruby Red Highlights.

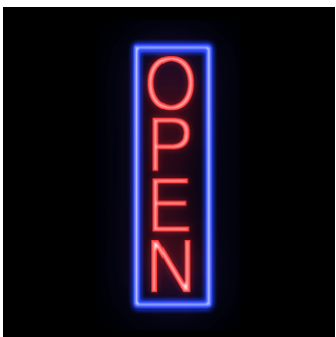

E

"Open" Neon Stock Sign Vertical. Letters Clear Red, Border Horizon

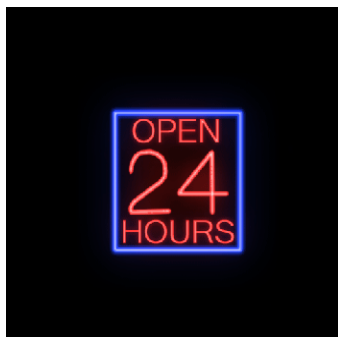

F

"Open 24 Hours" Neon Stock Sign. Letters Clear Red, Border Horizon



G

"Pizza" Neon Stock Sign. Letters Clear Red, Border Horizon Blue.



H

"Pizza" Neon Stock Sign. Letters Clear Red, No Border.



I

"Pizza & Dinners" Neon Stock Sign. Letters Clear Red, With Dead Border.



J

"Pizza & Grinders" Neon Stock Sign. Letters Clear Red, With Dead Border.



K

"Pizza" Neon Stock Sign. Letters Clear Red, No Border.



L

"Hot Oven Grinders" Neon Stock Sign. HOT - Clear Red, OVEN GRINDERS - Flo Green Border - 6500 White



M

"Grinders" Neon Stock Sign. Letters Clear Red, Border Horizon Blue.



N

"Grinders" Neon Stock Sign. Letters Clear Red, No Border.



O

"Subs" Neon Stock Sign. Letters Clear Red, Border Horizon Blue.



P

"Gyros" Neon Stock Sign. Letters Clear Red, Border Horizon Blue.



Q

"Pasta" Neon Stock Sign. Letters Clear Red, Border Horizon Blue.



R

"Salads" Neon Stock Sign. Letters Flo Green, Border 6500 White.



S

"Deli" Neon Stock Sign. Letters Flo Green, Border 6500 White.



T

"Fish & Chips" Neon Stock Sign. Letters Clear Red, Border Horizon Blue.



U

"Dinner" Neon Stock Sign. Letters Clear Red, Border Horizon Blue.



V

"Lunch" Neon Stock Sign. Letters Clear Red, Border Horizon Blue.

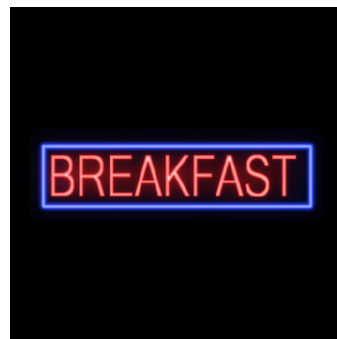

W

"Breakfast" Neon Stock Sign. Letters Clear Red, Border Horizon Blue.

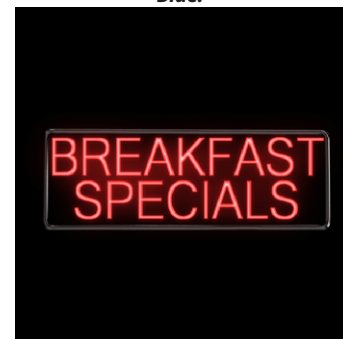

X

"Breakfast Specials" Neon Stock Sign. Letters Clear Red, Dead Border.

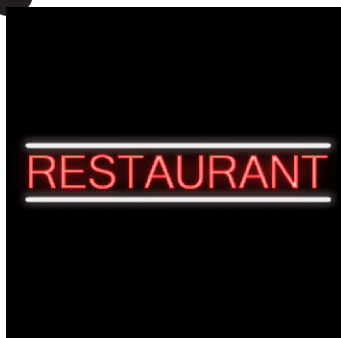

Y

"Restaurant" Neon Stock Sign. Letters Clear Red, Border 6500 White.

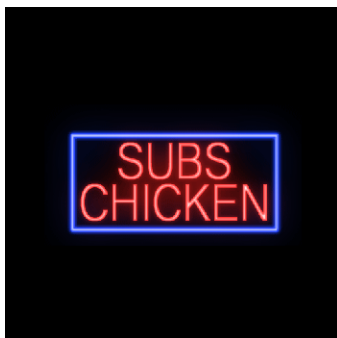

Z

"Subs Chicken" Neon Stock Sign. Letters Clear Red, Border Horizon Blue.

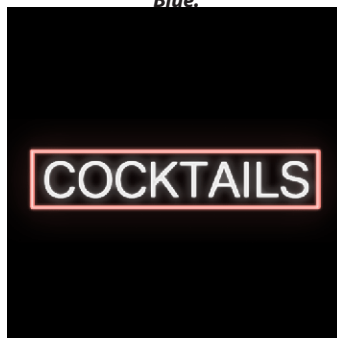

AA

"Cocktails" Neon Stock Sign. Letters 6500 White, Border Coral Pink.



AB

"Free Delivery" Neon Stock Sign. Letters Clear Red, Border Horizon.

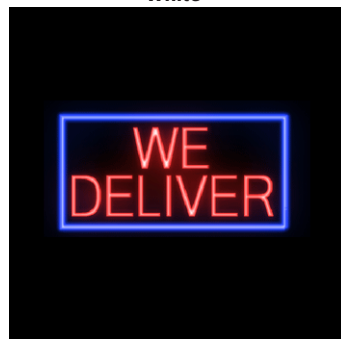

AC

"We Deliver" Neon Stock Sign. Letters Clear Red, Border Horizon Blue.

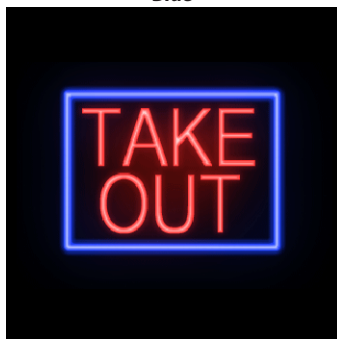

AD

"Take Out" Neon Stock Sign. Letters Clear Red, Border Horizon Blue.



AE

"Take Out" Oriental, Neon Stock Sign. Letters Clear Red, Border Clear Bright Yellow.



AF

"Lobster" Graphic Neon Stock Sign. Graphic Lobster Clear Red, No Border.

STOCK NEON SIGNS



AG

"Fresh" In Live Fish Graphic Neon Stock Sign. Letters Clear Red, Border Horizon Blue



AH

"Seafood" In Live Scallop Neon Stock Sign. Letters Turquoise, Border 6500 White



AI

"Coffee Cup" Graphic Neon Stock Sign. Cup Clear Brite Yellow, Steam White, Dead Border



AJ

"Coffee Cup" Graphic Neon Stock Sign. Cup Clear Brite Yellow, Steam White, No Border



AK

"Bakery" In Live Chefs Hat Neon Stock Sign. Letters Clear Red, Chef's Hat Border 6500 White



AL

"Bakery" Neon Stock Sign. Letters Clear Red, Border 6500 White



AM

"Soft Serve Cone" Graphic Neon Stock Sign. Cone Clear Brite Yellow, Ice Cream White



AN

"Old Fashion Cone" Graphic Neon Stock Sign. Cone Clear Brite Yellow, Ice Cream White



AO

"Frozen Yogurt" Neon Stock Sign Custom. Frozen Turquoise, Yogurt 6500 White



AP

"Alterations" Neon Stock Sign. Letters Horizon Blue, Border Clear Brite Yellow

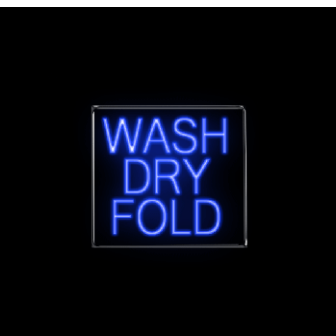

AQ

"Wash Dry Fold" Neon Stock Sign. Letters Horizon Blue, Dead Border

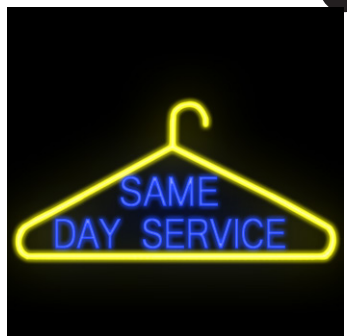

AR

"Same Day Service" In Live Coat Hanger Neon Stock Sign. Letters Horizon Blue, Coat Hanger Clear Brite Yellow



AS

"Dry Cleaning" Neon Stock Sign. Letters Horizon Blue, Border Clear Brite Yellow

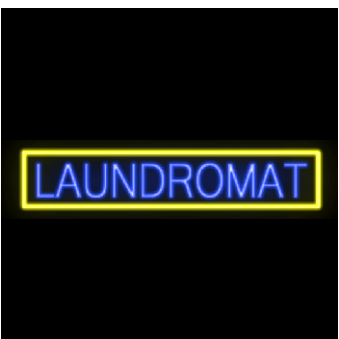

AT

"Laundromat" Neon Stock Sign. Letters Horizon Blue, Border Clear Brite Yellow

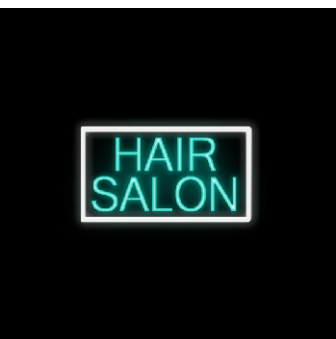

AU

"Hair Salon" Neon Stock Sign. Letters Turquoise, Border 6500 White

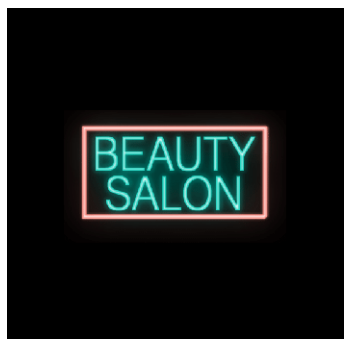

AV

"Beauty Salon" Neon Stock Sign. Letters Turquoise, Border Coral Pink



AW

"Scissor Graphic" Neon Stock Sign. Scissor 6500 White

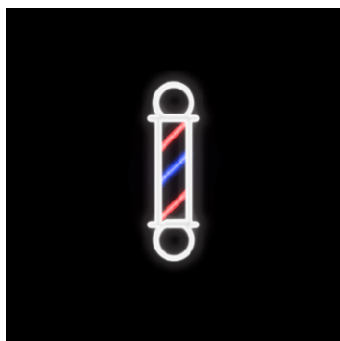

AX

"Barber Shop Post" Graphic Neon Stock Sign. Post 6500 White. Clear Red Stripe and Horizon Blue



AY

"Tanning" Custom with Sun Neon Stock Sign. Sun Clear Red, Clear Brite Yellow Rays, Letters 6500 White, No Border

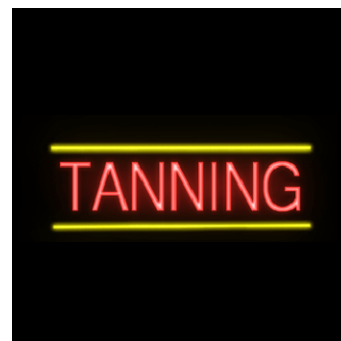

AZ

"Tanning" Neon Stock Sign. Letters Clear Red, Lines Clear Brite Yellow

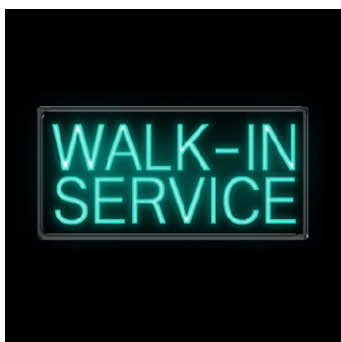

BA

"Walk-In Service" Neon Stock Sign. Letters Turquoise, Dead Border



BB

"CD's" In Live Circle Neon Stock Sign. Letters Turquoise, Border Coral Pink. Letters Turquoise, Border Coral Pink



BC

"Records" Neon Stock Sign. Letters Turquoise, Border Coral Pink

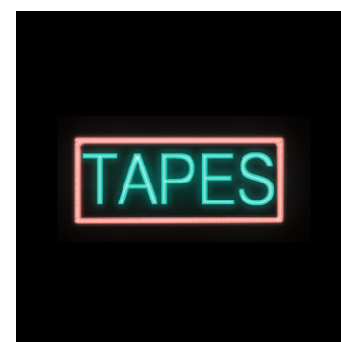

BD

"Tapes" Neon Stock Sign. Letters Turquoise, Border Coral Pink



BE

Guitar Graphic Neon Stock Sign. Horizon Blue, No Border



BF

"Auto Care" Neon Stock Sign. Letter Clear Red, Border 6500 White



BG

"Auto Parts" Neon Stock Sign. Letter Clear Red, Border 6500 White



BH

"Sales" Neon Stock Sign. Letter Clear Red, Border Horizon Blue

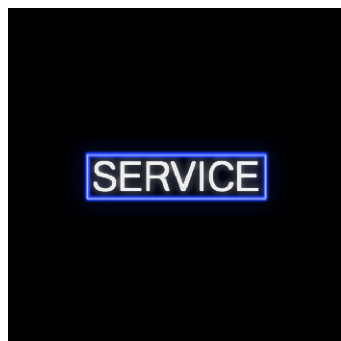

BI

"Service" Neon Stock Sign. Letter Clear Red, Border Horizon Blue

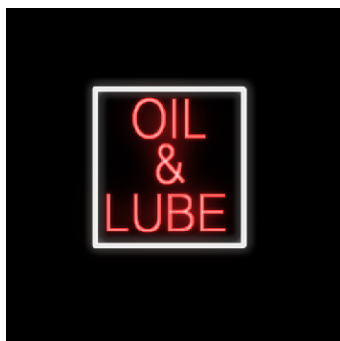

BJ

"Oil & Lube" Neon Stock Sign. Letter Clear Red, Border 6500 white

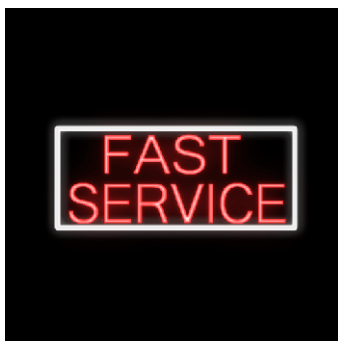

BK

"Fast Service" Neon Stock Sign. Letter Clear Red, Border 6500 white

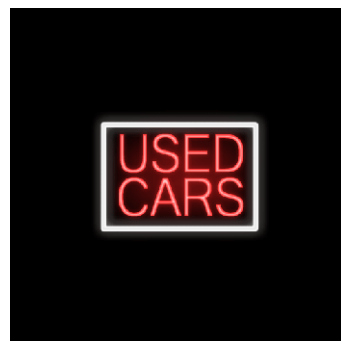

BL

"Used Cars" Neon Stock Sign. Letter Clear Red, Border 6500 white

STOCK NEON SIGNS



BM

"Video" Neon Stock Sign. Letters Turquoise, Border Coral Pink



BN

"Video" Neon Stock Sign. Letters Turquoise, No Border



BO

"Movie Rental" Neon Stock Sign. Letters Turquoise, Dead Border



BP

"Rentals" Neon Stock Sign. Letters 3500 White, Border Horizon Blue



BQ

"Video Rentals" Neon Stock Sign. Letters Turquoise, Border Coral Pink



BR

"Rx" With Mortar & Pestle Graphic Neon Stock Sign. Letters Horizon Blue, Mortar & Pestle 6500 White



BS

"Pharmacy" Neon Stock Sign. Letters Horizon Blue, Border 6500 White



BT

"Card & Gifts" Neon Stock Sign. Letters Coral Pink, Dead Border

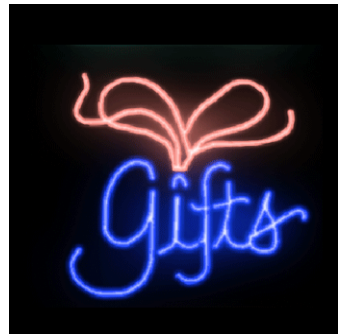

BU

"Gifts" Neon Stock Sign. Letters Horizon Blue, Ribbon Coral Pink, Dead Border



BV

"Gifts" Neon Stock Sign. Letters Coral Pink, Border Turquoise



BW

"Florist" Neon Stock Sign. Letters Flo Gree, Lines 6500 White

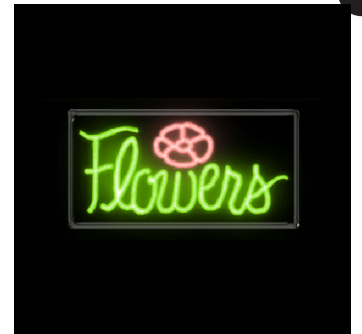

BX

"Flowers" Neon Stock Sign. Letters Flo Gree, Flower Coral Pink, Dead Border

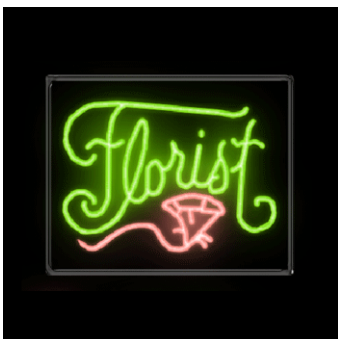

BY

"Florist" Neon Stock Sign. Letters Turquoise, Flower Flo Green & Coral Pink, Dead Border



BZ

"Flowers" Neon Stock Sign. Letters Flo Green, Lines 6500 White



CA

"Rose" Graphic Neon Stock Sign. Stem Flo Green, Rose Coral Pink



CB

"Printing" Neon Stock Sign. Letters 6500 White, Border Horizon Blue



CC

"Copies" Neon Stock Sign. Letters 6500 White, Border Horizon Blue

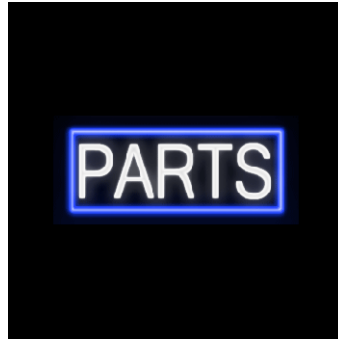

CD

"Parts" Neon Stock Sign. Letters 6500 White, Border Horizon Blue



CE

"Hardware" Neon Stock Sign. Letters Clear Red, Lines White



CF

"Aerobics" Neon Stock Sign. Letters Clear Red, Lines White

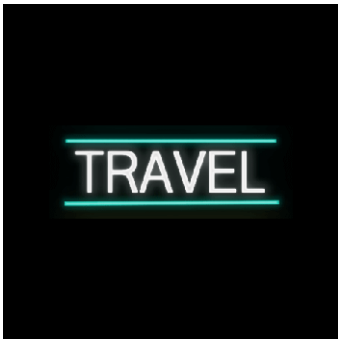

CG

"Travel" Neon Stock Sign. Letters Turquoise, Lines 6500 White

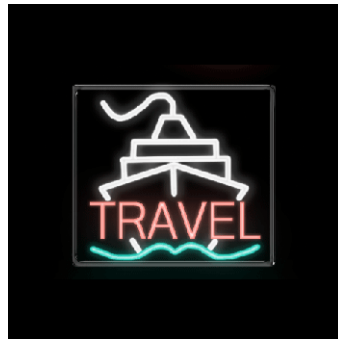

CH

"Travel" Custom Ship in Border Neon Stock Sign. Letters Coral Pink, Ship 650 White & Turquoise, Dead Border



CI

"Sunglasses" Graphic Neon Stock Sign. Sunglasses Clear Red, No Border



CJ

"1 Hour Photo" Neon Stock Sign. #1 Turquoise, Letters Rose, Dead Border

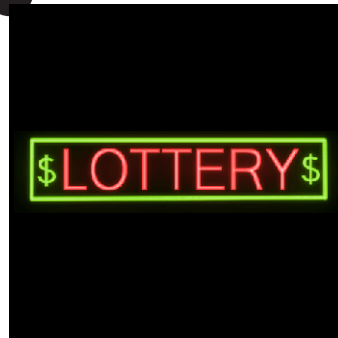

CK

"Lottery" Neon Stock Sign. Letters Clear Red, \$ and Border Flo Green



CL

"Diamond" Graphic Neon Stock Sign. Diamond White, No Border

SEE SPECIFICATIONS ON NEXT PAGE

STOCK NEON SIGNS

	SKU	LETTER HEIGHT	SIZE	TRANSFORMERS
	1-A/STOCK NEON	6"	10" x 24"	Mounted to PVC
A	1-C/STOCK NEON	12"	17" x 41"	Allanson Electronic Transformers: 9000/30
	1-F/STOCK NEON	6"	11" x 25"	Mounted to PVC
	1/STOCK NEON	6"	9.25" x 23"	Allanson Electronic Transformers: 9000/30
B	1-B/STOCK NEON	12"	6" x 20"	Allanson Electronic Transformers: 6000/30
	1-D/STOCK NEON	6"	12" x 36"	Allanson Electronic Transformers: 6000/30
C	1-E/STOCK NEON	6"	9.25" x 23"	Mounted to PVC
D	2/STOCK NEON	5" - 10"	14" x 25"	Allanson Electronic Transformers: 9000/30
E	3/STOCK NEON	5"	30" x 9"	Allanson Electronic Transformers: 9000/30
F	5-A/STOCK NEON	4" - 11"	24" x 24"	Allanson Electronic Transformers: 9000/30
G	5-B/STOCK NEON	6"	10" x 23"	Allanson Electronic Transformers: 6000/30
H	6/STOCK NEON	6"	6" x 19"	Allanson Electronic Transformers: 6000/30
I	7/STOCK NEON	6"	26" x 36"	Allanson Electronic Transformers: 12000/30
J	8/STOCK NEON	6"	26" x 36"	Allanson Electronic Transformers: 12000/30
K	9/STOCK NEON	6" & 12"	12" x 24"	Allanson Electronic Transformers: 9000/30
L	10-A/STOCK NEON	5"	30" x 36"	Allanson Electronic Transformers: 12000/30
M	10-B/STOCK NEON	6"	10" x 36"	Allanson Electronic Transformers: 12000/30
N	11/STOCK NEON	6"	6" x 24"	Allanson Electronic Transformers: 9000/30
O	12/STOCK NEON	6"	10" x 23"	Allanson Electronic Transformers: 6000/30
P	13/STOCK NEON	6"	10" x 31"	Allanson Electronic Transformers: 6000/30
Q	14/STOCK NEON	6"	10" x 22"	Allanson Electronic Transformers: 9000/30
R	15/STOCK NEON	6"	10" x 30"	Allanson Electronic Transformers: 9000/30
S	16/STOCK NEON	6"	10" x 19"	Allanson Electronic Transformers: 9000/30
T	17/STOCK NEON	5"	23" x 23"	Allanson Electronic Transformers: 9000/30
U	18/STOCK NEON	6"	10" x 32"	Allanson Electronic Transformers: 9000/30
V	19/STOCK NEON	6"	10" x 32"	Allanson Electronic Transformers: 9000/30
W	20/STOCK NEON	6"	10" x 39"	Allanson Electronic Transformers: 12000/30
X	21/STOCK NEON	5"	17" x 37"	Allanson Electronic Transformers: 12000/30
Y	22/STOCK NEON	5"	8" x 35"	Allanson Electronic Transformers: 9000/30
Z	23/STOCK NEON	5"	16" x 32"	Allanson Electronic Transformers: 12000/30
AA	24/STOCK NEON	5"	9" x 36"	Allanson Electronic Transformers: 9000/30
AB	25/STOCK NEON	5"	16" x 32"	Allanson Electronic Transformers: 9000/30
AC	26/STOCK NEON	5"	18" x 37"	Allanson Electronic Transformers: 12000/30
AD	27/STOCK NEON	5"	17" x 21"	Allanson Electronic Transformers: 9000/30
AE	28/STOCK NEON	5"	18" x 22"	Allanson Electronic Transformers: 9000/30
AF	28-A/STOCK NEON	n/a	18" x 30"	Allanson Electronic Transformers: 9000/30
AG	29/STOCK NEON	n/a	10" x 32"	Allanson Electronic Transformers: 6000/30
AH	30/STOCK NEON	5" - 15"	25" x 27"	Allanson Electronic Transformers: 9000/30
AI	31-A/STOCK NEON	n/a	18" x 24"	n/a

	SKU	LETTER HEIGHT	SIZE	TRANSFORMERS
AJ	31/STOCK NEON	n/a	20.5" x 27"	Allanson Electronic Tranformers: 9000/30
AK	32/STOCK NEON	4"	24" x 24"	Allanson Electronic Tranformers: 9000/30
AL	33/STOCK NEON	5"	9" x 23"	Allanson Electronic Tranformers: 6000/30
AM	34/STOCK NEON	n/a	12" x 28"	Allanson Electronic Tranformers: 9000/30
AN	35/STOCK NEON	n/a	12" x 28"	Allanson Electronic Tranformers: 9000/30
AO	36/STOCK NEON	n/a	26" x 32"	Allanson Electronic Tranformers: 9000/30
AP	37/STOCK NEON	5"	9" x 44"	Allanson Electronic Tranformers: 9000/30
AQ	38/STOCK NEON	5"	23" x 23"	Allanson Electronic Tranformers: 9000/30
AR	39/STOCK NEON	5"	23" x 49"	Allanson Electronic Tranformers: 12000/30
AS	40/ STOCK NEON	5"	15" x 33"	Allanson Electronic Tranformers: 12000/30
AT	41/STOCK NEON	5"	9" x 44"	Allanson Electronic Tranformers: 9000/30
AU	42/STOCK NEON	5"	16" x 23"	Allanson Electronic Tranformers: 9000/30
AV	43/STOCK NEON	6"	18" x 31"	Allanson Electronic Tranformers: 12000/30
AW	44/STOCK NEON	n/a	16" x 30"	Allanson Electronic Tranformers: 6000/30
AX	45/STOCK NEON	n/a	25" x 7"	n/a
AY	46/STOCK NEON	5"	22" x 35"	Allanson Electronic Tranformers: 9000/30
AZ	47/STOCK NEON	6"	10" x 31"	Allanson Electronic Tranformers: 9000/30
BA	48/STOCK NEON	5"	16" x 34"	Allanson Electronic Tranformers: 9000/30
BB	49/STOCK NEON	6"	19"	Allanson Electronic Tranformers: 6000/30
BC	50/STOCK NEON	6"	10" x 36"	Allanson Electronic Tranformers: 9000/30
BD	51/STOCK NEON	6"	10" x 28"	Allanson Electronic Tranformers: 6000/30
BE	52/STOCK NEON	n/a	13" x 39"	Allanson Electronic Tranformers: 6000/30
BF	53/STOCK NEON	5"	16" x 23"	Allanson Electronic Tranformers: 9000/30
BG	54/STOCK NEON	6"	18" x 24"	Allanson Electronic Tranformers: 9000/30
BH	55/STOCK NEON	6"	10" x 28"	Allanson Electronic Tranformers: 9000/30
BI	56/STOCK NEON	6"	10" x 36"	Allanson Electronic Tranformers: 9000/30
BJ	57/STOCK NEON	5"	23" x 22"	Allanson Electronic Tranformers: 9000/30
BK	58/STOCK NEON	5"	16" x 34"	Allanson Electronic Tranformers: 9000/30
BL	59/STOCK NEON	6"	18" x 22"	Allanson Electronic Tranformers: 9000/30
BM	60A/STOCK NEON	6"	10" x 30"	Allanson Electronic Tranformers: 9000/30
BN	60B/STOCK NEON	6"	6" x 22"	Allanson Electronic Tranformers: 6000/30
BO	61/STOCK NEON	5"	16" x 35"	Allanson Electronic Tranformers: 12000/30
BP	62/STOCK NEON	6"	10" x 36"	Allanson Electronic Tranformers: 9000/30
BQ	63/STOCK NEON	6"	18" x 29"	Allanson Electronic Tranformers: 9000/30
BR	64/STOCK NEON	8"	34" x 26"	Allanson Electronic Tranformers: 9000/30
BS	65/STOCK NEON	5"	9" x 36"	Allanson Electronic Tranformers: 9000/30
BT	66/STOCK NEON	6"	26" x 33"	Allanson Electronic Tranformers: 9000/30
BU	67/STOCK NEON	n/a	31" x 33"	Allanson Electronic Tranformers: 9000/30
BV	68/STOCK NEON	6"	10" x 23"	Allanson Electronic Tranformers: 6000/30

STOCK NEON SIGNS

	SKU	LETTER HEIGHT	SIZE	TRANSFORMERS
BW	1-A/STOCK NEON	6"	10" x 31"	Allanson Electronic Transformers: 6000/30
BX	1/STOCK NEON	7" & 14"	18" x 36"	Allanson Electronic Transformers: 9000/30
BY	1-E/STOCK NEON	n/a	26" x 35"	Allanson Electronic Transformers: 12000/30
BZ	2/STOCK NEON	6"	10" x 36"	Allanson Electronic Transformers: 9000/30
CA	3/STOCK NEON	n/a	21" x 46"	Allanson Electronic Transformers: 6000/30
CB	5-A/STOCK NEON	6"	10" x 36"	Allanson Electronic Transformers: 9000/30
CC	5-B/STOCK NEON	6"	10" x 28"	Allanson Electronic Transformers: 9000/30
CD	6/STOCK NEON	6"	10" x 27"	Allanson Electronic Transformers: 6000/30
CE	7/STOCK NEON	5"	9" x 32"	Allanson Electronic Transformers: 9000/30
CF	8/STOCK NEON	6"	10" x 36"	Allanson Electronic Transformers: 9000/30
CG	9/STOCK NEON	6"	10" x 29"	Allanson Electronic Transformers: 9000/30
CH	10-A/STOCK NEON	6"	32" x 33"	Allanson Electronic Transformers: 12000/30
CI	10-B/STOCK NEON	5" - 12"	16" x 30"	Allanson Electronic Transformers: 9000/30
CJ	11/STOCK NEON	5"	16" x 30"	Allanson Electronic Transformers: 9000/30
CK	12/STOCK NEON	5"	9" x 36"	Allanson Electronic Transformers: 9000/30
CL	13/STOCK NEON	n/a	16" x 21"	Allanson Electronic Transformers: 6000/30

Annapolis Arch



Graphic Area: 37"x25"

Single Faced Sign

Special Order Only

Sold Without Graphics

"Annapolis Arch" by Carvagio was created for America's towns and historic districts. This product is made from cast HDU (high density urethane), comes shipped primed white, and can be painted, routed, gold leafed. High quality outdoor latex, and oil base paints can be used. However, for best results, use high quality outdoor latex paints. It will not rot, swell, crack, or split even after prolonged outdoor exposure. The Annapolis Arch comes in one size at 42"x30"x3", and can be mounted onto a side of a building, or on posts dug into the ground. The graphic area is approx 2.5" smaller on all sides from the product size. This product is **SPECIAL ORDER** only.

SKU

AA-42x30

SIZE

42" x 30" x 3"

Jefferson Presidential Collection

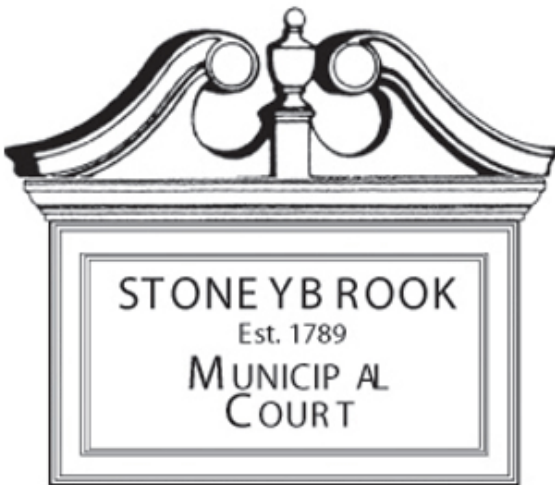

Graphic Area: 54"x44"

Single Faced Sign

Special Order Only

Sold Without Graphics

"Presidential Collection" by Carvagio was created for America's towns and historic districts. This product is made from cast HDU (high density urethane), comes shipped primed white, and can be painted, routed, gold leafed. It will not rot, swell, crack, or split even after prolonged outdoor exposure. High quality outdoor latex, and oil base paints can be used. However, for best results, use high quality outdoor latex paints. The Presidential Jefferson comes in the large size at 59"x49"x3.5", and can be mounted onto a side of a building, or on posts dug into the ground. The graphic area is approx 2.5" smaller on all sides from the product size. This product is **SPECIAL ORDER** only.

SKU

J-59x49

SIZE

59" x 49" x 3.5"

Mount Vernon Collection Small Tablet



Graphic Area: 7"x8"
Single Faced Sign
Special Order Only
Sold Without Graphics

"Mount Vernon by Carvagio was created for America's towns and historic districts. This product is made from cast HDU (high density urethane), comes shipped primed white, and can be painted, routed, gold leafed. High quality outdoor latex, and oil base paints can be used. However, for best results, use high quality outdoor latex paints. It will not rot, swell, crack, or split even after prolonged outdoor exposure. The Mount Vernon Collection comes in the small size at 11"x12"x1.25", and can be mounted onto a side of a building. The price below is for a box of 2 small Mount Vernon Tablets. The graphic area is approx 2" smaller on all sides from the product size. This product is **SPECIAL ORDER** only.

SKU
MV-11x12

SIZE
 11" x 12" x 1.25"

Mount Vernon Collection Small Tablet



Overall Size: 19"x22"x1.50"
Graphic Area: 15"x18"
Single Faced Sign
Special Order Only
Sold Without Graphics

"Mount Vernon by Carvagio was created for America's towns and historic districts. This product is made from cast HDU (high density urethane), comes shipped primed white, and can be painted, routed, gold leafed. High quality outdoor latex, and oil base paints can be used. However, for best results, use high quality outdoor latex paints. It will not rot, swell, crack, or split even after prolonged outdoor exposure. The Mount Vernon Collection comes in the medium size at 12"x22"x1.50", and can be mounted onto a side of a building. The price below is for a box of 2 medium Mount Vernon Tablets. The graphic area is approx 2" smaller on all sides from the product size. This product is **SPECIAL ORDER** only.

SKU
MV-11x12

SIZE
 11" x 12" x 1.25"

Oakwood Oval Collection Large

Graphic Area: 12"x23"x1.50"
 Single Faced Sign
 Special Order Only
 Sold Without Graphics

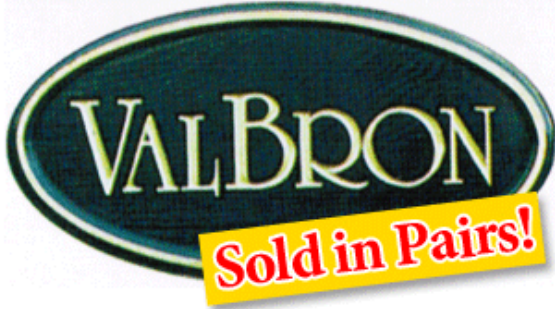

"Oakwood Oval" by Carvagio was created for America's towns and historic districts. This product is made from cast HDU (high density urethane), comes shipped primed white, and can be painted, routed, gold leafed. It will not rot, swell, crack, or split even after prolonged outdoor exposure. The Oakwood Oval comes in the large Size at 12"x23"x1.50", and can be mounted onto a side of a building. The price below is for a box of 2 large Oakwood Oval's. The graphic area is approx 2.25" smaller on all sides from the product size. This product is **SPECIAL ORDER** only.

SKU
 00-12x23

SIZE
 12" x 23" x 1.50"

Oakwood Oval Collection Medium

Graphic Area: 8.5"x11.50"
 Single Faced Sign
 Special Order Only
 Sold Without Graphics



"Oakwood Oval" by Carvagio was created for America's towns and historic districts. This product is made from cast HDU (high density urethane), comes shipped primed white, and can be painted, routed, gold leafed. It will not rot, swell, crack, or split even after prolonged outdoor exposure. High quality outdoor latex, and oil base paints can be used. However, for best results, use high quality outdoor latex paints. The Oakwood Oval comes in the Medium Size at 13"x16"x1.50", and can be mounted onto a side of a building. The price below is for a box of 2 medium Oakwood Oval's. The graphic area is approx 2.25" smaller on all sides from the product size. This product is **SPECIAL ORDER** only.

SKU
 00-13x16

SIZE
 13" x 16" x 1.50"

Madison Presidential Collection



Graphic Area: 54"x44"
Single Faced Sign
Special Order Only
Sold Without Graphics

"Madison Presidential Collection" by Carvagio was created for America's towns and historic districts. This product is made from cast HDU (high density urethane), comes shipped primed white, and can be painted, routed or gold leafed. It will not rot, swell, crack, or split even after prolonged outdoor exposure. High quality outdoor latex, and oil base paints can be used. However, for best results, use high quality outdoor latex paints. The Presidential Jefferson comes in the large size at 59"x49"x3.5", and can be mounted onto a side of a building, or on posts dug into the ground. The graphic area is approx 2.5" smaller on all sides from the product size. This product is **SPECIAL ORDER** only.

SKU
M-59x49

SIZE
59" x 49" x 3.5"

Oakwood Oval Collection Extra Large



Graphic Area: 30.75"x40.75"
Single Faced Sign
Special Order Only
Sold Without Graphics

"Oakwood Oval" by Carvagio was created for America's towns and historic districts. This product is made from cast HDU (high density urethane), comes shipped primed white, and can be painted, routed, gold leafed. It will not rot, swell, crack, or split even after prolonged outdoor exposure. High quality outdoor latex, and oil base paints can be used. However, for best results, use high quality outdoor latex paints. The Oakwood Oval comes in the Extra Large Size at 33"x43"x3.5", and can be mounted onto a side of a building. The graphic area is approx 2.25" smaller on all sides from the product size. This product is **SPECIAL ORDER** only.

SKU
OO-33x43

SIZE
33" x 43" x 3.5"

Oakwood Oval Collection Small



Graphic Area: 5"x7"
Single Faced Sign
Special Order Only
Sold Without Graphics

"Oakwood Oval" by Carvagio was created for America's towns and historic districts. This product is made from cast HDU (high density urethane), comes shipped primed white, and can be painted, routed, gold leafed. It will not rot, swell, crack, or split even after prolonged outdoor exposure. High quality outdoor latex, and oil base paints can be used. However, for best results, use high quality outdoor latex paints. The Oakwood Oval comes in the small size at 9.5"x11.5"x1", and can be mounted onto a side of a building. The price below is for a box of 2 small Oakwood Oval's. The graphic area is approx 2" smaller on all sides from the product size. This product is **SPECIAL ORDER** only.

SKU
OO-9x11

SIZE
9.5" x 11.5" x 1"

Olde Towne Collection Banner Large



Graphic Area: 9"x55"
Single Faced Sign
Special Order Only
Sold Without Graphics

"Olde Towne" by Carvagio was created for America's towns and historic districts. This product is made from cast HDU (high density urethane), comes shipped primed white, and can be painted, routed, gold leafed. It will not rot, swell, crack, or split even after prolonged outdoor exposure. High quality outdoor latex, and oil base paints can be used. However, for best results, use high quality outdoor latex paints. The Olde Towne Banner comes in the large size at 13"x59"x1.50", and can be mounted onto a side of a building. The graphic area is approx 2" smaller on all sides from the product size. This product is **SPECIAL ORDER** only.

SKU
OT-13x59

SIZE
13" x 59" x 1.50"

Olde Towne Collection Classic Oval



Graphic Area: 15"x19"
Single Faced Sign
Special Order Only
Sold Without Graphics

"Olde Towne" by Carvagio was created for America's towns and historic districts. This product is made from cast HDU (high density urethane), comes shipped primed white, and can be painted, routed, gold leafed. It will not rot, swell, crack, or split even after prolonged outdoor exposure. High quality outdoor latex, and oil base paints can be used. However, for best results, use high quality outdoor latex paints. The Olde Towne Classic Oval comes in one size at 19"x23"x1.5", and can be mounted onto a side of a building, or can be connected to post dug into the ground. The price below is for a box of 2 Classic Oval's. The graphic area is approx 2" smaller on all sides from the product size. This product is **SPECIAL ORDER** only.

SKU
OT-19x23

SIZE
19" x 23" x 1.5"

Olde Towne Collection Medium Tablet



Graphic Area: 25"x21"
Single Faced Sign
Special Order Only
Sold Without Graphics

"Olde Towne" by Carvagio was created for America's towns and historic districts. This product is made from cast HDU (high density urethane), comes shipped primed white, and can be painted, routed or gold leafed. It will not rot, swell, crack, or split even after prolonged outdoor exposure. High quality outdoor latex, and oil base paints can be used. However, for best results, use high quality outdoor latex paints. The Olde Towne Tablet comes in the Medium size at 30"x26"x3.5", and can be mounted onto a side of a building, or can be connected to post dug into the ground. The graphic area is approx 2.5" smaller on all sides from the product size. This product is **SPECIAL ORDER** only.

SKU
OT-30x26

SIZE
30" x 26" x 3.5"

Olde Towne Collection Large Tablet

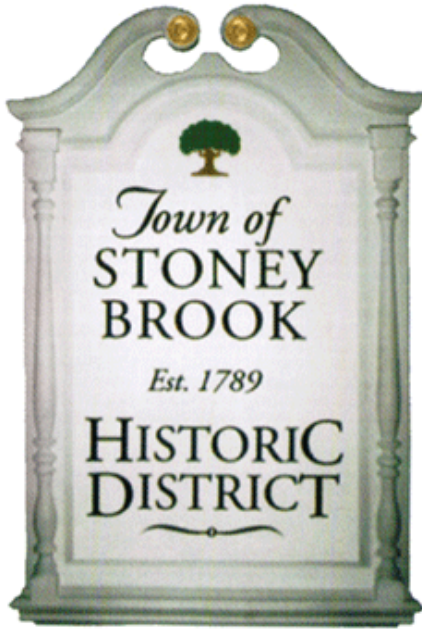

Graphic Area: 37.5"x23.5"

Single Faced Sign

Special Order Only

Sold Without Graphics

"Olde Towne" by Carvagio was created for America's towns and historic districts. This product is made from cast HDU (high density urethane), comes shipped primed white, and can be painted, routed or gold leafed. It will not rot, swell, crack, or split even after prolonged outdoor exposure. High quality outdoor latex, and oil base paints can be used. However, for best results, use high quality outdoor latex paints. The Olde Towne Tablet comes in the large size at 40"x26"x3.5", and can be mounted onto a side of a building, or can be connected to post dug into the ground. The graphic area is approx 2.5" smaller on all sides from the product size. This product is **SPECIAL ORDER** only.

SKU

OT-40x26

SIZE

40" x 26" x 3.5"

Olde Towne Collection Classic Banner



Single Faced Sign

Special Order Only

Sold Without Graphics

"Olde Towne" by Carvagio was created for America's towns and historic districts. This product is made from cast HDU (high density urethane), comes shipped primed white, and can be painted, routed or gold leafed. It will not rot, swell, crack, or split even after prolonged outdoor exposure. High quality outdoor latex, and oil base paints can be used. However, for best results, use high quality outdoor latex paints. The Olde Towne Classic Banner and can be mounted onto a side of a building, or can be connected to post dug into the ground. The graphic area is approx 2.5" smaller on all sides from the product size. This product is **SPECIAL ORDER** only.

SKU

OT-7x32

SIZE

7.5" x 32" x 1"

Olde Towne Collection Banner Medium

Graphic Area: 5"x36"
Single Faced Sign
Special Order Only
Sold Without Graphics



"Olde Towne" by Carvagio was created for America's towns and historic districts. This product is made from cast HDU (high density urethane), comes shipped primed white, and can be painted, routed or gold leafed. It will not rot, swell, crack, or split even after prolonged outdoor exposure. High quality outdoor latex, and oil base paints can be used. However, for best results, use high quality outdoor latex paints. The Olde Towne Banner comes in the medium size at 9"x40"x1.50", and can be mounted onto a side of a building. The graphic area is approx 2" smaller on all sides from the product size. This product is **SPECIAL ORDER** only.

SKU
OT-9x40

SIZE
9" x 40" x 1.50"

Princeton Peak

Graphic Area: 37"x27"
Single Faced Sign
Special Order Only
Sold Without Graphics

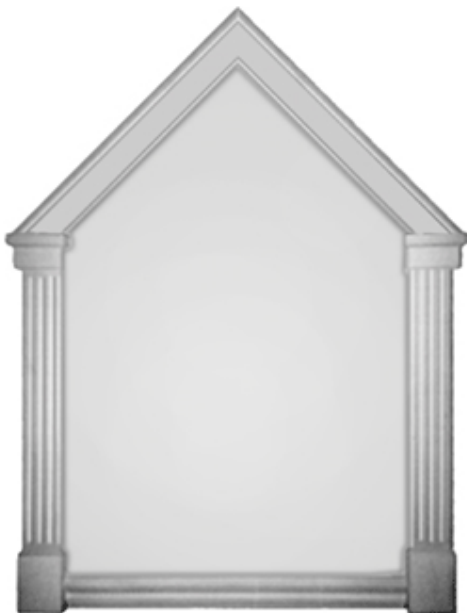

"Princeton Peak" by Carvagio wasThis product is made from cast HDU (high density urethane), comes shipped primed white, and can be painted, routed, gold leafed. High quality outdoor latex, and oil base paints can be used. However, for best results, use high quality outdoor latex paints. It will not rot, swell, crack, or split even after prolonged outdoor exposure. The Princeton Peak comes in one size at 42"x30"x3.5", and can be mounted onto a side of a building. The graphic area is approx 3" smaller on all sides from the product size. This product is **SPECIAL ORDER** only.

SKU
PP-43x30

SIZE
43" x 30" x 3.5"

Savannah Rose Plaque

Graphic Area: 8"x11"
Single Faced Sign
Special Order Only
Sold Without Graphics



Sold in Pairs!

"Savannah Rose" by Carvagio was created for America's towns and historic districts. This product is made from cast HDU (high density urethane), comes shipped primed white, and can be painted, routed, gold leafed. It will not rot, swell, crack, or split even after prolonged outdoor exposure. High quality outdoor latex, and oil base paints can be used. However, for best results, use high quality outdoor latex paints. The Savannah Rose comes in once size at 13"x16"x1.50", and can be mounted onto a side of a building. The price below is for a box of 2 Savannah Rose Plaques. The graphic area is approx 2.5" smaller on all sides from the product size. This product is **SPECIAL ORDER** only.

SKU
OT-9x40

SIZE
 9" x 40" x 1.50"

Washington 44" Presidential Collection

Graphic Area: 54"x39"
Single Faced Sign
Special Order Only
Sold Without Graphics



"Presidential Collection" by Carvagio was created for America's towns and historic districts. This product is made from cast HDU (high density urethane), comes shipped primed white, and can be painted, routed, gold leafed. It will not rot, swell, crack, or split even after prolonged outdoor exposure. High quality outdoor latex, and oil base paints can be used. However, for best results, use high quality outdoor latex paints. The Presidential comes in the large size at 59"x44"x3.5", and can be mounted onto a side of a building, or on posts dug into the ground. The graphic area is approx 2.5" smaller on all sides from the product size. This product is **SPECIAL ORDER** only.

SKU
W-59x44

SIZE
 59" x 44" x 3.5"

Washington 52" Presidential Collection

Graphic Area: 54"x47"
Single Faced Sign
Special Order Only
Sold Without Graphics



"Presidential Collection" by Carvagio was created for America's towns and historic districts. This product is made from cast HDU (high density urethane), comes shipped primed white, and can be painted, routed, gold leafed. It will not rot, swell, crack, or split even after prolonged outdoor exposure. High quality outdoor latex, and oil base paints can be used. However, for best results, use high quality outdoor latex paints. The Presidential comes in the medium size at 59"x52"x3.5", and can be mounted onto a side of a building, or on posts dug into the ground. The graphic area is approx 2.5" smaller on all sides from the product size. This product is **SPECIAL ORDER** only.

SKU
W-59x52

SIZE
59" x 52" x 3.5"

Yorktown Plaque

Graphic Area: 19"x26"
Single Faced Sign
Special Order Only
Sold Without Graphics



"Yorktown" by Carvagio was created for America's towns and historic districts. This product is made from cast HDU (high density urethane), comes shipped primed white, and can be painted, routed, gold leafed. High quality outdoor latex, and oil base paints can be used. However, for best results, use high quality outdoor latex paints. It will not rot, swell, crack, or split even after prolonged outdoor exposure. The Yorktown comes in one size at 21"x27"x1.25", and can be mounted onto a side of a building. The price below is for a box of 2 Yorktown Plaques. The graphic area is approx 1" smaller on all sides from the product size. This product is **SPECIAL ORDER** only.

SKU
Y-21x28

SIZE
21" x 28" x 1.25"

Flex Changeable Letters .030

A B C D E F G H I J K L M N O P
Q R S T U V W X Y Z
! % , / & . - \$ * ¢ →
0 1 2 3 4 5 6 7 8

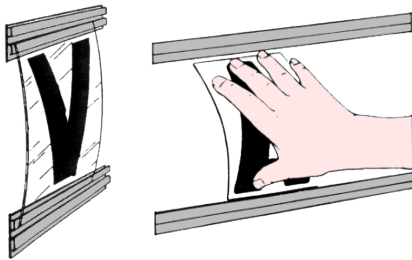

Flex Letter Set - 4" Height - .030" Thickness (Bold)

Flex Changeable Copy Letters and Numbers Set is a low-cost economical letter set. With its clear PVC backing, these letters are not designed to be laid flat against surfaces. They must be bowed to allow wind to pass for expansion and contraction. Flex Changeable Copy Letters and Numbers must be used in a well vented application. They cannot be used in a non-vented vandal-proof application due to the fact that they heat and warp. **Used with Texas Track only!**

Character	Quantity	Color
A E I N O R S T	12	Black
L	8	Black
B C D F G H J K M P U Y	6	Black
Q V W X Z , &	4	Black
! % / . -	2	Black
6	8	Red
5	5	Red
0 1 2 3 4 7 8 * !	4	Red
. ¢ \$ - →	2	Red
Total	273	

SKU

HEIGHT

4-FLEX-BOLD(48)

4"

A B C D E F G H I J K L M N O P
Q R S T U V W X Y Z
! % , / & . - \$ * ¢ →
0 1 2 3 4 5 6 7 8

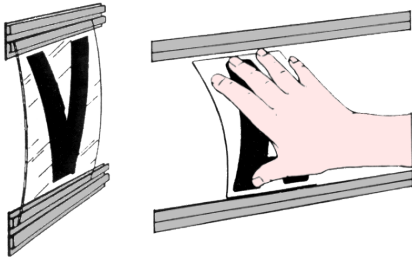

Flex Letter Set - 6" Height - .030" Thickness (Bold)

Flex Changeable Copy Letters and Numbers Set is a low-cost economical letter set. With its clear PVC backing, these letters are not designed to be laid flat against surfaces. They must be bowed to allow wind to pass for expansion and contraction. Flex Changeable Copy Letters and Numbers must be used in a well vented application. They cannot be used in a non-vented vandal-proof application due to the fact that they heat and warp. **Used with Texas Track only!**

Character	Quantity	Color
A E N O R S T	12	Black
B C D F G H I J K L M P Q U V X Y Z	6	Black
0 1 2 3 4 5 6 7 8 9	6	Black
% ¢ - . \$	6	Black
Total	288	

SKU

HEIGHT

6-FLEX-BOLD(46)

6"

CHANGEABLE COPY LETTERS AND TRACK

ABCDEFGHIJKLMNPO
 QRSTUVWXYZ
 ! % , / & . - \$ * ¢ →
 012345678

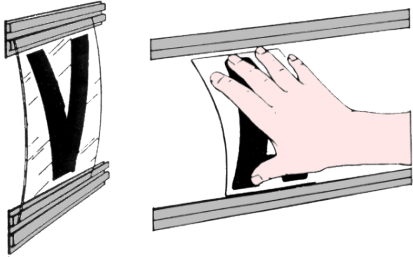

Flex Letter Set - 6" Height - .030" Thickness (Bold)

Flex Changeable Copy Letters and Numbers Set is a low-cost economical letter set. With its clear PVC backing, these letters are not designed to be laid flat against surfaces. They must be bowed to allow wind to pass for expansion and contraction. Flex Changeable Copy Letters and Numbers must be used in a well vented application. They cannot be used in a non-vented vandal-proof application due to the fact that they heat and warp. **Used with Texas Track only!**

Character	Quantity	Color
A E N O R S T	12	Black
B C D F G H I J K L M P Q U V X Y Z	6	Black
0 1 2 3 4 5 6 7 8 9	6	Black
% ¢ - . \$	6	Black
Total	288	

SKU

HEIGHT

6-FLEX-BOLD(46)

6"

ABCDEFGHIJKLMNPO
 QRSTUVWXYZ
 & % / . - * !
 123456780

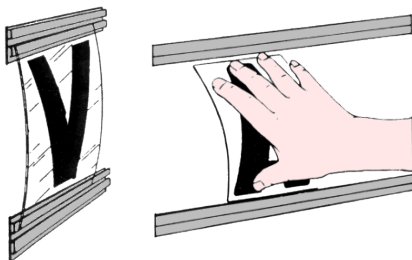

Flex Letter Set - 6" Height - .030" Thickness (Condensed)

Flex Changeable Copy Letters and Numbers Set is a low-cost economical letter set. With its clear PVC backing, these letters are not designed to be laid flat against surfaces. They must be bowed to allow wind to pass for expansion and contraction. Flex Changeable Copy Letters and Numbers must be used in a well vented application. They cannot be used in a non-vented vandal-proof application due to the fact that they heat and warp. **Used with Texas Track only!**

Character	Quantity	Color
A E I N R S	12	Black
O T	8	Black
B C D F G H J K L M P U	6	Black
Q V W X Y Z . - * !	4	Black
% /	2	Black
0 6	12	Red
5	9	Red
1 2 3 4 7 8 \$	6	Red
Total	279	

SKU

HEIGHT

6-FLEX-COND(44)

6"

A B C D E F G H I J K L M N O P
Q R S T U V W X Y Z
! % , / & . - \$ * ¢ →
0 1 2 3 4 5 6 7 8

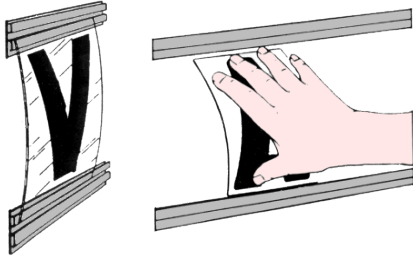

Flex Letter Set - 8" Height - .030" Thickness (Bold)

Flex Changeable Copy Letters and Numbers Set is a low-cost economical letter set. With its clear PVC backing, these letters are not designed to be laid flat against surfaces. They must be bowed to allow wind to pass for expansion and contraction. Flex Changeable Copy Letters and Numbers must be used in a well vented application. They cannot be used in a non-vented vandal-proof application due to the fact that they heat and warp. **Used with Texas Track only!**

Character	Quantity	Color
A E I N O R S T	12	Black
B C D G H J L Q U W : , ! .	8	Black
F K M P V X Y Z % - ? " "	6	Black
" #	4	Black
6	2	Red
0 1 2 3 4 5 7 8 - \$ ¢	12	Red
& * /	9	Red
Total	312	

SKU

8-FLEX-BOLD(36)

HEIGHT

8"

DON'T FORGET!



Texas Track (For Flex Letters - 7'6" - .040" Thickness)

This Letter Track holds Flex Changeable Copy Letters and Numbers Set onto any Sign. The Texas Track is made of Polycarbonate plastic with a length of 7'6" long (or 90 inches) and can be cut to the sign size you need. To attach you can drill a hole at the center of the track and use screws or rivets or screws into your letter board. You can also use double-sided VHB tape to secure it as well as glue.

SKU: 7-6-TT (94)

CHANGEABLE COPY LETTERS AND TRACK

Rigid .080

Pronto Rigid Letter Set .080" Thickness

Pronto Changeable Copy Letters and Numbers Set is a cut above the traditional saw-cut changeable copy. Its patented acrylic panel design prevents scratches and its UV Inks have no harmful VOCs. It also has molded feet to keep panels from sticking within the track. **Used with Pronto Track only!**

**ABCDEFGHIJKLMN O P
Q R S T U V W X Y Z & ¢
1 2 3 4 5 6 7 8 9 0**



Character	Quantity	Color
E	12	Black
A I	8	Black
O U	6	Black
L N R S T P	4	Black
F G H M	2	Black
B C D	8	Red
J K V W Y Z	5	Red
Q X \$ ¢	4	Red
. ¢ \$ - →	2	Red
Total	250	

SKU	HEIGHT
4-PRONTO	4"
6-PRONTO	6"
*8-PRONTO	8"

*300 letters

DON'T FORGET ABOUT YOUR ADDITIONAL ACCESSORIES!

PRONTO LETTER TRACKS (.250 THICKNESS)

SKU: D-PRONTO (8")
D-PRONTO-12 (12")

Dual Track

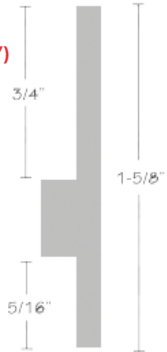

SKU: T-PRONTO (8")
T-PRONTO-12 (12")

Top Track

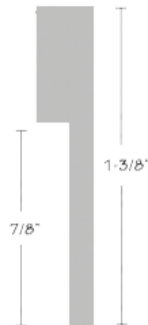

SKU: B-PRONTO (8")
B-PRONTO-12 (12")

Bottom Track

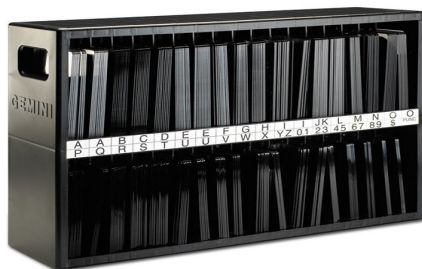
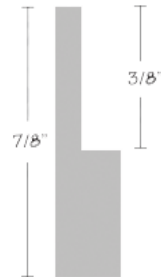

PRONTO LETTER SET STORAGE CABINET

SKU	PRONTO LETTER HEIGHT
4-STORAGE	4"
6-STORAGE	6"
8-STORAGE	8"



Pronto Change Arms
6'-18' w/3-3/4" Standard Cup
SKU: 3318

White Basic Banner 10oz. with Grommets



Standard 10 oz. laminated vinyl. Vinyl graphics, screen inks, water based enamels & solvent and water based digital inks. Longer term outdoor use, fire retardant for indoors. Grommets in corners and every 2'-3'. Up to 6' wide in one piece. White and colors (Yellow, Blue, Red, Black Green). 10 oz. std. banners finish as follows: 24", 33" & 48".

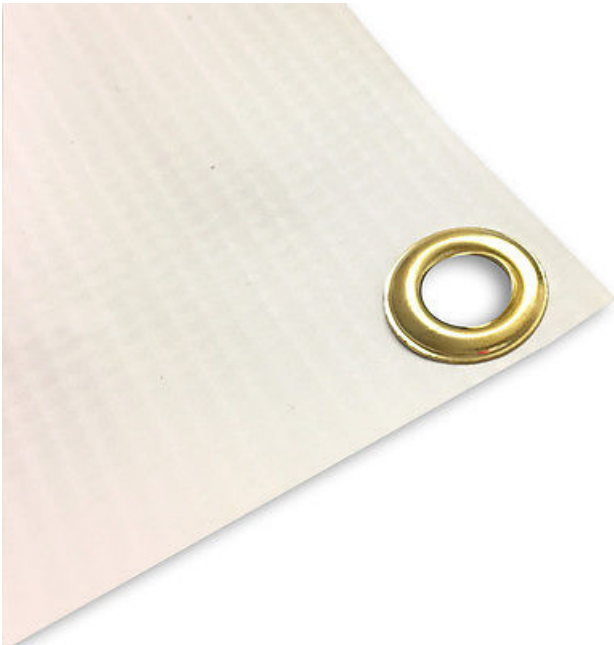

SKU	SIZE
100Z-VR2X10	24" x 10'
100Z-VR2X12	24" x 12'
100Z-VR2X4	24" x 4'
100Z-VR2X6	24" x 6'
100Z-VR2X8	24" x 8'
100Z-VR3X10	33" x 10'
100Z-VR3X12	33" x 12'
100Z-VR3X4	33" x 4'
100Z-VR3X6	33" x 6'
100Z-VR3X8	33" x 8'
100Z-VR4X10	48" x 10'
100Z-VR4X12	48" x 12'
100Z-VR4X4	48" x 4'
100Z-VR4X6	48" x 6'
100Z-VR4X8	48" x 8'

Symbols

3-2287 3, 21
7521 Mesh 3, 27
8518 3, 16
48000 Series 3, 33

A

Air Release 4, 52
Application 21, 28, 29, 30, 31, 32, 33
Aqueous 24
Arlon 3210 3, 14, 15, 37
Arlon 3220 3, 14, 15
Arlon 3270 14, 17
Arlon 3420 3, 14, 18
Arlon 3510 3, 18

B

C

CADdigital PU 3, 30
CADdigital PVC 3, 30
Cast Ultra Gloss Clear Vinyl 15
Clean Removing, Repositionable Adhesive 6
Clear Solvent Adhesive 4, 5, 6, 7, 8, 9, 10, 11, 12, 14, 15, 16,
18, 19, 20, 21, 22, 23, 32, 37, 52
ColorPrint PU 3, 30

D

digital media 13
Digital Print Pressure-Sensitive Vinyl Film 8
DPF 206 3, 20
DPF 207 3, 20
DPF 210 3, 21, 28, 34
DPF 303 3, 27
DPF 313 3, 26
DPF 315 3, 26
DPF 390 3, 27
DPF 510 8
DPF 2400 3, 32
DPF 4500 G 3, 7, 19
DPF 4500 GLX/MLX 7
DPF 4560 GT 7
DPF 4600LX 4, 12
DPF 6000 RP CLEAR 5
DPF 6000 XRP 5
DPF 6100 XLP 4
DPF 6500 3, 4, 22, 52
DPF 8000 5
Dye Block 3, 31

E

EconoMag 3, 23
Eco-Satin 3, 24

Eco-Solvent 4, 5, 6, 7, 8, 9, 10, 11, 12, 13, 19, 21, 22, 23, 24, 25, 26,
27, 28, 29, 30, 31, 32, 33, 34, 35, 52
Exterior 21

F

FDC 7270 3, 10, 22
FDC 7521Mesh 22
Fleet Graphics 5, 6, 15, 17, 37
Flite Technology 13
FLITE Technology 6

G

GFCVM 35
GFIOP212 3, 24
GF Photo 3, 24, 25
GF Photo 240 3, 25
Graphics 4, 5, 6, 7, 10, 15, 17, 18, 19, 20, 22, 26, 27, 32, 37

H

High Resolution 24, 25

I

Industrial Grade Film for Hard-to-Stick Surfaces 5
Intermediate 3, 7, 9, 10, 18, 22
Intermediate Calendered Digital Vinyl Film 7
Intermediate Calendered Overlamine 18
Intermediate Calendered Print Media 7
Intermediate Grade Calendered PVC Digital Media 9, 10
Intermediate Grade Calendered Translucent Vinyl 10, 22
Intermediate Printable-Removable Matte Vinyl 10

J

K

L

Latex 4, 5, 6, 7, 8, 9, 10, 11, 12, 13, 19, 20, 21, 22, 23, 24, 25, 26, 27,
28, 29, 30, 31, 32, 33, 35, 52
Low Tack 23

M

M8500 Series 3, 33
Magnetic 23
Media 3, 4, 7, 8, 9, 10, 11, 12, 13, 19, 20, 21, 27

N

O

Optically Clear Premium Cast PVC Laminating Film 16
Oraguard 210 3, 18, 20
Oraguard 215 3, 19

Oraguard 290 3, 16
 Oraguard 290F 16
 Orajet 3164 9
 Orajet 3165 9
 Orajet 3551RA 3, 10
 Orajet 3620 3, 20
 Orajet 3621 9
 Orajet 3640 8
 Orajet 3641 8
 Orajet 3751RA 6
 Orajet 3850 3, 11, 21
 Oralite 5600 3, 32
 Oralite 5650RA 3, 32
 overlaminate 13, 15, 17

P

Partial Wrap 4, 5, 6, 10, 12, 13, 14, 15, 16, 17, 18, 19, 32, 37
 Polyester 21, 26, 27, 28, 29, 30, 31, 34
 Polypropylene 23
 POP Displays 4, 7, 8, 18, 19, 24, 26
 Posters 23, 24
 Premium 3, 4, 5, 6, 12, 13, 15, 16, 17, 18, 21, 22, 28, 34, 36, 37, 52
 Premium Cast Digital Film 6
 Premium Cast Overlaminate Pressure-Sensitive Film 15, 17, 37
 Premium Cast PVC Laminating Film 16
 Premium Clear Cast Film 4
 Premium Gloss Print Media 4
 Premium Translucent Cast Film 4, 52
 Printable 3, 10, 19, 23, 24, 29, 31, 32
 Printable Overlaminate & Media Digital Film 19
 PVC 3, 5, 8, 9, 10, 16, 18, 19, 20, 26, 27, 28, 30
 PVC Laminating Film 16, 18, 19

Q**R**

Rapid Air 10, 32
 Real Estate Signage 4, 7, 8
 Reflective 3, 32
 Removable Coated Wall Fabric 20
 Removable Decoration Vinyl 20
 Repositionable 4, 5, 6, 10, 12, 13, 22, 23, 52
 Retroreflective 33
 Ritrama 3-8957 3, 15
 Ritrama 3-9292 3, 10

S

Scotchcal Gloss Overlaminate 16
 Second Surface Signs 4, 52
 Semi -Rigid 21, 28, 34
 Short to Medium-Term 8
 Short to Medium-Term Signage 7
 SLX Cast Wrap 6
 Soft Calendered PVC Digital Media 8, 9
 Solvent 4, 5, 6, 7, 8, 9, 10, 11, 12, 13, 14, 15, 16, 18, 19, 20, 21, 22,

23, 24, 25, 26, 27, 28, 29, 30, 31, 32, 33, 34, 35, 37, 52
 Solvent- Based Adhesives 11
 Stick2 3, 23

T

Top Value 3 Flag 3, 29
 Top Value 13 Standard Banner 3, 29
 Top Value 13 Super 3, 28
 Top Value 18 Super 3, 28
 Tradeshow Displays 7
 Tradeshow Graphics 4, 20
 Translucent Calendered Digital Media 11, 21
 Transparent 20

U

UV 4, 5, 6, 7, 8, 9, 10, 11, 12, 13, 14, 15, 16, 18, 19, 20, 21,
 22, 23, 24, 25, 26, 27, 28, 29, 31, 32, 52

V

Vehicle Wraps 4, 5, 6, 15, 18, 37

W

Water Based Adhesive 8, 9, 10, 20
 White Opaque 3, 31
 Window 4, 10, 15, 18, 20, 21, 23, 24, 25
 Window Graphics 4, 10, 15, 18, 20
 Windows 4, 52
 Wrap Kit 3, 4, 5, 12, 14, 15, 18, 37
 Wrapping Cast Film 6

X

X-Scape System 7

Y**Z**



Kirk Dexter
President

38 Years

800-327-7562

k.dexter@nepcosignsupply.com



Richard Sutton
General Manager

28 Years

800-327-7562

r.sutton@nepcosignsupply.com



Kaimen Blomgren
Equipment Technician

800-327-7562 x140

k.blomgren@nepcosignsupply.com



Lynn Diminico
Inside Sales

22 Years

800-327-7562 x122

l.diminico@nepcosignsupply.com



Shane Ferrara
Inside Sales

4 Years

800-327-7562 x115

s.ferrara@nepcosignsupply.com



Gary Martins
Inside Sales
Sign & Awning Specialist

15 Years

800-327-7562 x121

g.martins@nepcosignsupply.com



Gene Medeiros
Purchasing
& Inside Sales
Sign & Awning Specialist

20 Years

800-327-7562 x131

g.medeiros@nepcosignsupply.com



Leeana Nito
Web & Marketing
Director

1 Year

800-327-7562 x119

l.nito@nepcosignsupply.com

The Best Support Staff in the Industry!



Sarah Ducharme
Purchasing

10 Years

Ext. 112

s.ducharme@nepcosignsupply.com



Mindy Baker
Accounts
Receivable

Ext. 118

m.baker@nepcosignsupply.com



Tony Corveno
Office
Assistant

26 Years

Ext. 136

t.corveno@nepcosignsupply.com



Susan Dexter
Office
Manager

20 Years

Ext. 138

s.dexter@nepcosignsupply.com



Jeanette Fernandes
Office
Assistant

15 Years

Ext. 139

j.fernandes@nepcosignsupply.com



David Keane
Product
Returns

8 Years

Ext. 125

d.keane@nepcosignsupply.com



Tom Grant
Accounts
Receivable

5 Years

Ext. 111

t.grant@nepcosignsupply.com



Vanessa English
Accounts
Payable

Ext. 126

v.english@nepcosignsupply.com



Donna Bator
Accounts
Dept

2 Years

Ext. 132

d.bator@nepcosignsupply.com



Michele Achilli
Billing

1 Year

Ext. 124

billing@nepcosignsupply.com



Jim Munro
Warehouse
Manager &
Neon
Specialist

23 Years

warehouse@nepcosignsupply.com



Joe Bento
Warehouse
& Neon

14 Years



Nancy Carroll
Warehouse,
Deliveries &
Neon

5 Years



Derrick Silva
Warehouse

1 Year



Mike Hurteau

Warehouse
& UPS

2 Years